

CRa

PROFIELOVERZICHT	9
APERCU DES PROFILES	
PROFILUEBERSICHT	
PROFILE OVERVIEW	

CRb

TOEBEHOREN	23
ACCESSOIRES	
ZUBEHORTEILE	
ACCESSORIES	

CRc

STATICA	29
STATIQUE	
STATIK	
STATICS	

CRd

DOORSNEDETEKENINGEN.....	39
SECTION DE NOEUDS	
PROFILKOMBINATIONEN	
SECTION DRAWINGS	

CRe

ZAAGTABELLEN	51
COUPES ET DEBITS	
ZUSCHNITTSTABELLEN	
FABRICATION CHARTS	

CRf

WERKTEKENINGEN	55
DESSINS DE CONSTRUCTION	
KONSTRUKTIONZEICHNUNGEN	
CONSTRUCTION DRAWINGS	

aliplast
member of



CORIALIS

Comfort Roof

De tekeningen die voorgesteld zijn op schaal 1:1, kunnen kleine maatafwijkingen vertonen, te wijten aan de reproductietechniek van deze catalogoog.

Les dessins représentés à l'échelle 1 peuvent avoir de légères variations dimensionnelles dues aux techniques de reproduction de ce catalogue.

Die Zeichnungen im Maßstab 1:1 können aus technischen Reproduktionsgründen leichte Messung Schwankungen darstellen.

The drawings represented on a scale 1 basis may have light dimensional variations due to the reproduction of the manual.

DATUM	PAGINA	OMSCHRIJVING
DATE	PAGE	DESCRIPTION
DATUM	SEITE	BESCHREIBUNG
DATE	PAGE	DESCRIPTION
12/09/2012	3	<ul style="list-style-type: none"> - NIEUW HOOFDSTUK WIJZIGINGEN TOEGEVOEGD - NOUVEAU CHAPITRE MODIFICATIONS AJOUTEES - NEU KAPITEL ÄNDERUNGEN HINZUGEFÜGT - NEW CHAPTER CHANGES ADDED
19/09/2012	9	<ul style="list-style-type: none"> - UPDATE VERKRIJGBARE LENGTES - MISE A JOUR LONGUEURS DISPONIBLES - AKTUALISIERUNG VERFÜGBAR LÄNGEN - UPDATE AVAILABLE LENGTHS

PROFIELEN - PROFILS - PROFILE - PROFILES

GOOTPROFIEL _____	P. 13
GOUTTIERE	
DACHRINNE	
GUTTER PROFILE	
VERHOOGPROFIEL GOOT _____	P. 14
PROFIL DE REHAUSSEMENT	
ERHOHUNGSPROFIL DACHRINNE	
PLATFORM PROFILE	
VERSTEVIIGINGSPROFIELEN _____	P. 15
PROFILS DE REINFORCEMENT	
VERSTARKUNGSPROFIELEN	
STRENGHTENING PROFILES	
LIGGER EN SCHARNIERPROFIEL _____	P. 16
CHEVRON ET PROFILE DE CHARNIERE	
TRAGER UND SCHARNIERPROFIL	
ROOF BEAM AND HINGE PROFILE	
MUURPROFIELEN _____	P. 17
PROFILS MURAL	
MAUERPROFIELEN	
WALLPROFILES	
KAP EN PAAL PROFIEL _____	P. 18
CAPOT ET POTEAU PROFIL	
KAP UND PFAHL PROFIL	
COVER AND POST PROFILE	
ALU AFDEKKLIPS _____	P. 19
CLIPS EN ALU	
ALU KLIPSE	
ALU GLAZING CAPS	
POLYCARBONAATPROFIELEN _____	P. 20
PROFILS POLYCARBONAT	
FALZLEISTENPROFIELEN	
POLYCARBONATE PROFILES	
PVC KLIPS VOOR POLYCARBONAAT _____	P. 21
CLIPS PVC POUR POLYCARBONAT	
PVC KLIPSE FUR POLYCARBONAT	
PVC PROFILE FOR POLYCARBONATE	
GLASVERDELINGSPROFIELEN _____	P. 22
PROFILS POUR REPARTION VERRE	
PROFIELEN FUR GLASVERTEILUNG	
PROFILES FOR GLASSDIVISION	

ZAAGTABELLEN - TABLES DE SCIAGES ZUSCHNITT-TABELLEN - SAWING TABLES

ZAAGTABEL MET POLYCARBONAAT _____	P. 51
TABLE DE SCIAGE AVEC POLYCARBONATE	
ZUSCHNITT-TABELLEN MIT POLYCARBONAT	
SAWING TABLES WITH POLYCARBONATE	
ZAAGTABEL MET ENKEL GLAS _____	P. 52
TABLE DE SCIAGE AVEC VITRAGE SIMPLE	
ZUSCHNITT-TABELLEN MIT EINZIGES GLAS	
SAWING TABLES WITH SINGLE GLAZING	
BEREKENING C1/C2/Y _____	P. 53
CALCULATION C1/C2/Y	
BEREICHNUNG C1/C2/Y	
CALCULATION C1/C2/Y	

WERKTEKENINGEN - DESSINS DE CONSTRUCTION

KONSTRUKTIONZEICHNUNGEN - CONSTRUCTION DRAWINGS

INBOUWVOORBEELD _____	P. 55
EXEMPLE D'INSTALLATION	
EINBAUBEISPIEL	
INSTALLATION EXAMPLE	
MONTAGE ACCR110 _____	P. 56
MONTAGE ACCR110	
MONTAGE ACCR110	
MONTAGE ACCR110	
MONTAGE CR100 OP VR171 MET ACVR171 _____	P. 57
MONTAGE CR100 SUR VR171 AVEC ACVR171	
MONTAGE CR100 AUF VR171 MIT ACVR171	
MONTAGE CR100 AT VR171 WITH ACVR171	
MONTAGE CR100 OP VR171 MET ACCR322 _____	P. 58
MONTAGE CR100 SUR VR171 AVEC ACCR322	
MONTAGE CR100 AUF VR171 MIT ACCR322	
MONTAGE CR100 AUF VR171 MIT ACCR322	
MONTAGE ACCR2227 _____	P. 59
MONTAGE ACCR2227	
MONTAGE ACCR2227	
MONTAGE ACCR2227	
MONTAGE LIGGER OP GOOT _____	P. 60
MONTAGE CHEVRON SUR GOUTTIERE	
MONTAGE TRAGER AUF DACHRINNE	
MONTAGE ROOF BEAM AT GUTTER	
MONTAGE MUURPROFIELEN _____	P. 61
MONTAGE PROFILS MURAL	
MONTAGE MAUERPROFIELEN	
MONTAGE WALLPROFILES	
MONTAGE ACCR140 _____	P. 62
MONTAGE ACCR140	
MONTAGE ACCR140	
MONTAGE ACCR140	
MONTAGE VR515 _____	P. 63
MONTAGE VR515	
MONTAGE VR515	
MONTAGE VR515	
MONTAGE SCHARNIERPROFIEL _____	P. 64
MONTAGE PROFILE DE CHARNIERE	
MONTAGE SCHARNIERPROFIL	
MONTAGE HINGE PROFILE	

WERKTEKENINGEN - DESSINS DE CONSTRUCTION

KONSTRUKTIONZEICHNUNGEN - CONSTRUCTION DRAWINGS

MONTAGE VR040 _____ P. 66

MONTAGE VR040

MONTAGE VR040

MONTAGE VR040

MONTAGE POLYCARBONAAT _____ P. 67

MONTAGE POLYCARBONAT

MONTAGE POLYCARBONAT

MONTAGE POLYCARBONATE

MONTAGE ALU KLIPS _____ P. 68

MONTAGE CLIPS ALU

MONTAGE ALU KLIPSE

MONTAGE ALU CLIPS

MONTAGE ACCR112 _____ P. 70

MONTAGE ACCR112

MONTAGE ACCR112

MONTAGE ACCR112

MONTAGE CR150 _____ P. 71

MONTAGE CR150

MONTAGE CR150

MONTAGE CR150

MONTAGE MC055 _____ P. 72

MONTAGE MC055

MONTAGE MC055









MONTAGE MC055

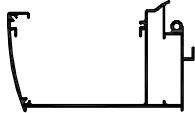



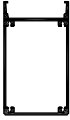

MONTAGE CR105 _____ P. 74





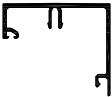

MONTAGE CR105

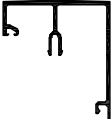
MONTAGE CR105



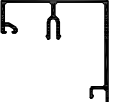





MONTAGE CR105

NUMMER NUMERO NUMBER NUMBER	AFBEELDING IMAGE BILD PICTURE	OMSCHRIJVING DESCRIPTION BESCHREIBUNG DESCRIPTION	LENGTE LONG LANGE LENGTH
CRI00		Gootprofiel Gouttière Dachrinne Gutter profile	5m 7m
CRI05		Verhoogprofiel voor goot Profil de rehaussement pour gouttière Erhöhungsprofil für Dachrinne Raise profile for gutter	5m 7m
CRI06		Plat staal 60/12mm Meplat en acier 60/12mm Rechteckstange aus Stahl 60/12mm Rectangular bar of steel 60/12mm	6m
CRI08		Plat staal 80/12mm Meplat en acier 80/12mm Rechteckstange aus Stahl 80/12mm Rectangular bar of steel 80/12mm	6m
CRI10		Scharnierprofiel Profile charnière Scharnierprofil Hinge profile	7m
CRI11		Scharnierprofiel Profile charnière Scharnierprofil Hinge profile	5m 7m
CRI20		Ligger 100mm Chevron 100mm Trager 100mm Roof beam 100mm	5m 7m
CRI26		U profiel in staal 50X70X4 Profil U en acier 50X70X4 U profiel aus Stahl 50X70X4 U profile of steel 50X70X4	4.7m

NUMMER NUMERO NUMBER NUMBER	AFBEELDING IMAGE BILD PICTURE	OMSCHRIJVING DESCRIPTION BESCHREIBUNG DESCRIPTION	LENGTE LONG LANGE LENGTH
CRI30		Variabele kogel nok Rotule faitage variable Kugelgelenk first variabel Ridge socket variable	7m
CRI40		Binnendeel muurprofiel Profil intérieur mural Mauerprofil innen Wall profil inside	5m 7m
CRI50		Buitendeel muurprofiel Profil extérieur mural Mauerprofil aussen Wall profil outside	5m 7m
CRI72		Kap voor paal Capot pour poteau Kappe für Pfahl Cover for post	2.75m 5.5m
VR030		Alu afdekklips Clips en alu Alu Klipse Alu glazing cap	7m
VR031		Alu afdekklips Clips en alu Alu Klipse Alu glazing cap	7m
VR032		Alu afdekklips Clips en alu Alu Klipse Alu glazing cap	7m
VR033		Alu afdekklips Clips en alu Alu Klipse Alu glazing cap	7m

NUMMER NUMERO NUMBER NUMBER	AFBEELDING IMAGE BILD PICTURE	OMSCHRIJVING DESCRIPTION BESCHREIBUNG DESCRIPTION	LENGTE LONG LANGE LENGTH
VR034		Alu afdeklips Clips en alu Alu Klipse Alu glazing cap	7m
VR035		Alu afdeklips Clips en alu Alu Klipse Alu glazing cap	7m
VR036		Alu afdeklips Clips en alu Alu Klipse Alu glazing cap	7m
VR037		Alu afdeklips Clips en alu Alu Klipse Alu glazing cap	7m
VR040		Polycarbonaatprofiel 16mm Profil polycarbonat 16mm Falzleistenprofil 16mm polycarbonate profile 16mm	7m
VR041		Polycarbonaatprofiel 32mm Profil polycarbonat 32mm Falzleistenprofil 32mm polycarbonate profile 32mm	7m
VR043		Polycarbonaatprofiel 20mm Profil polycarbonat 20mm Falzleistenprofil 20mm polycarbonate profile 20mm	7m
VR044		Polycarbonaatprofiel 25mm Profil polycarbonat 25mm Falzleistenprofil 25mm polycarbonate profile 25mm	7m

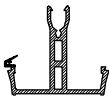
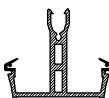
PROFIELEN - PROFILS - PROFILE - PROFILES

NUMMER NUMERO NUMBER	AFBEELDING IMAGE BILD PICTURE	OMSCHRIJVING DESCRIPTION BESCHREIBUNG DESCRIPTION	LENGTE LONG LANGE LENGTH
VR171		Paal Poteau Pfahl Post 	2.75m 5.5m
VR425		Binnendeel muurprofiel Profil intérieur mural Mauerprofil innen Wall profil inside 	5m 7m
VR426		Buitendeel muurprofiel Profil extérieur mural Mauerprofil aussen Wall profil outside 	5m 7m
VR515A		Pvc clips voor polycarbonaat Clips pvc pour polycarbonat Pvc clipse fur polycarbonat Pvc profile for polycarbonat PVC	7m
VR515		Pvc clips voor polycarbonaat Clips pvc pour polycarbonat Pvc clipse fur polycarbonat Pvc profile for polycarbonat PVC	7m
VR2030		Tussenregel dakprofiel travers profil toiture Sprossenprofil Dach Intermediate glazing profile	3.5m 7m
MC055		Klemprofiel Profil de serrage Druckleiste Sub-profile	7m

GOOTPROFIEL
 GOUTTIERE
 DACHRINNE
 GUTTER PROFILE

CR100

PROFIELEN - PROFILS - PROFILE - PROFILES

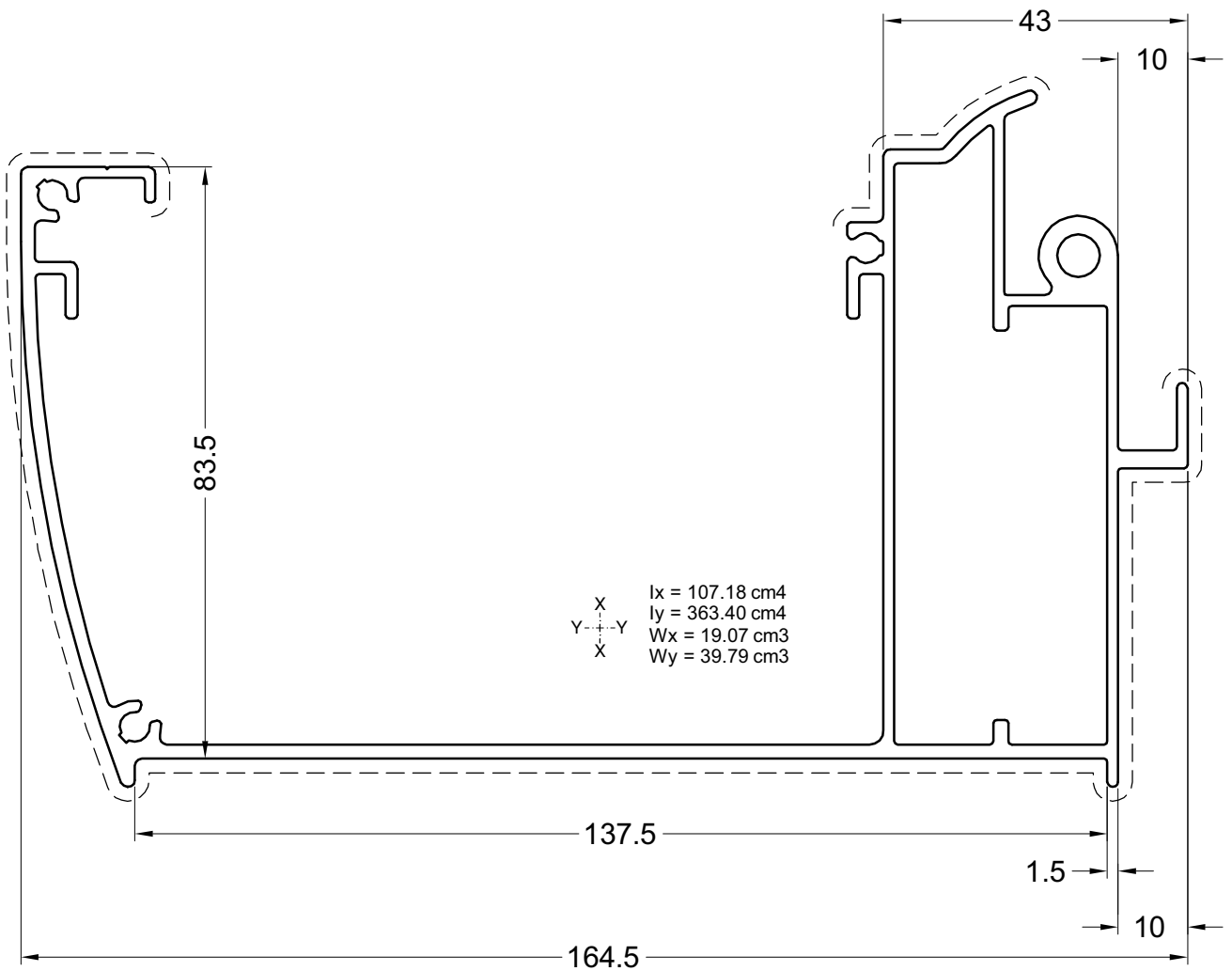

CRa01

VERHOOGPROFIEL GOOT
PROFIL DE REHAUSSEMENT
ERHOHUNGSPROFIL DACHRINNE
PLATFORM GUTTER

CR105

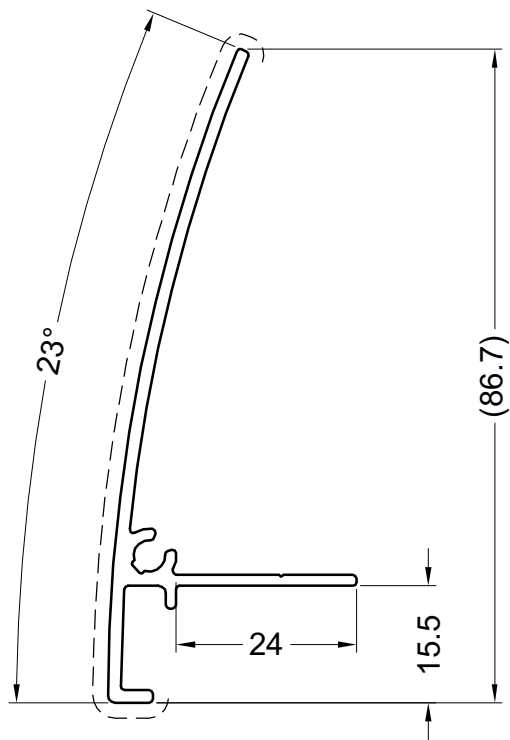

CRa02

VERSTEVIGINGSPROFIELEN
 PROFILS DE REINFORCEMENT
 VERSTÄRKUNGSPROFIELEN
 STRENGTHENING PROFILES

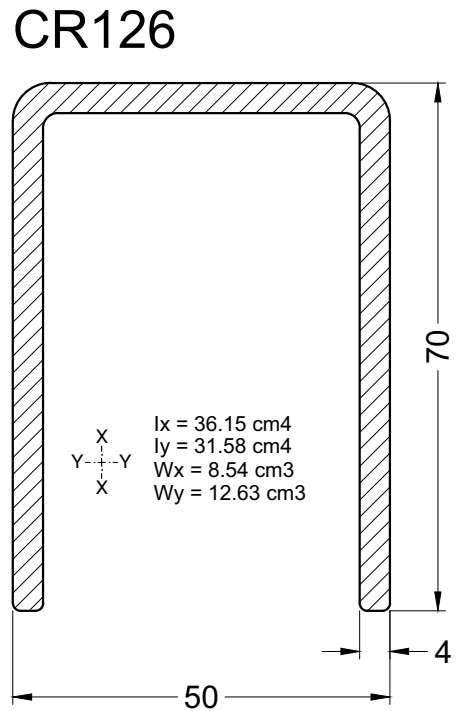
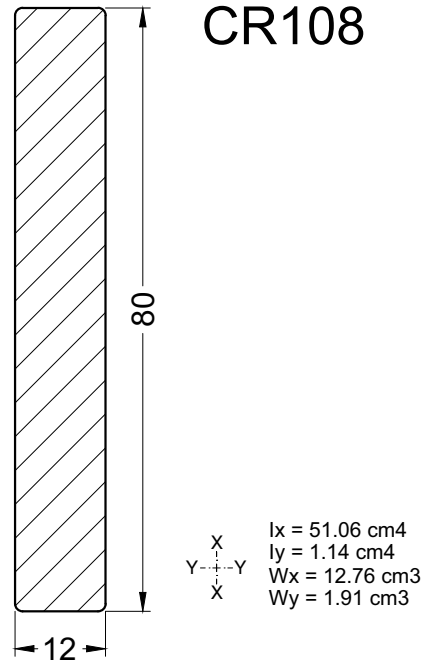
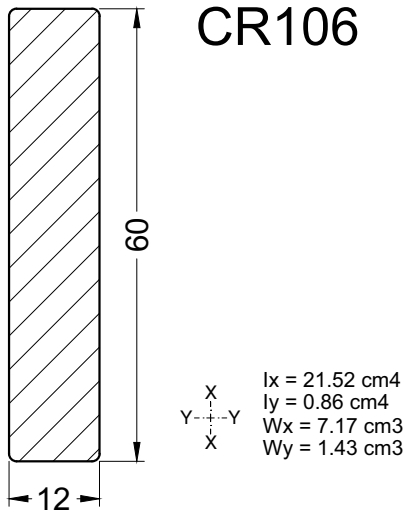

PROFIELEN - PROFILS - PROFILE - PROFILES

CRa03

**LIGGER EN SCHARNIERPROFIELEN
CHEVRON ET PROFILES CHARNIERES
TRAGER UND SCHARNIERPROFIL
ROOF BEAM AND HINGE PROFILES**

CR110

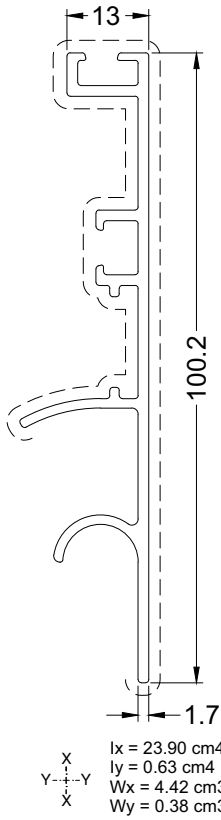

CR111

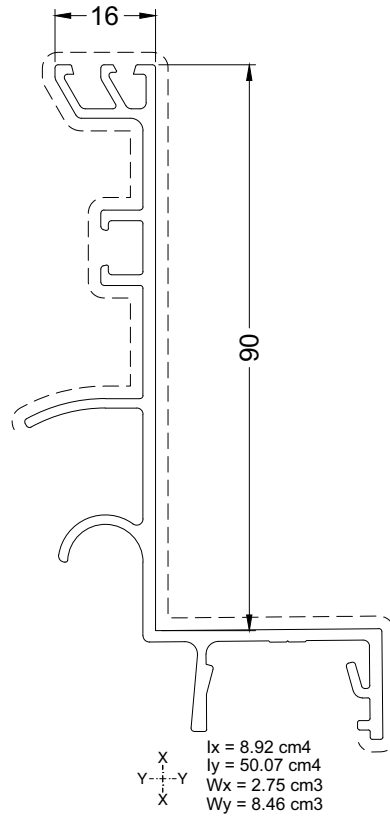

CR120

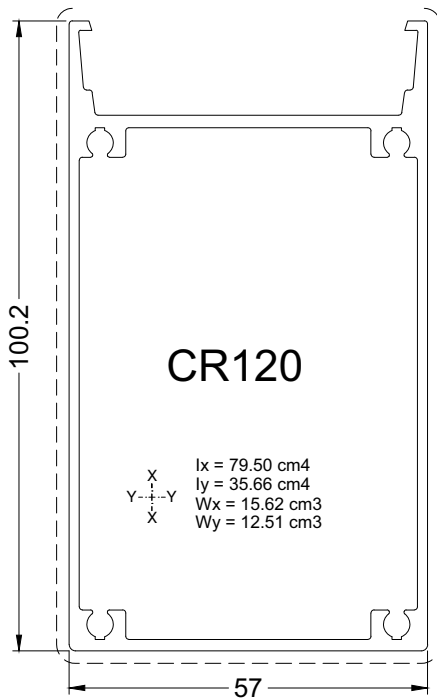

VR011N

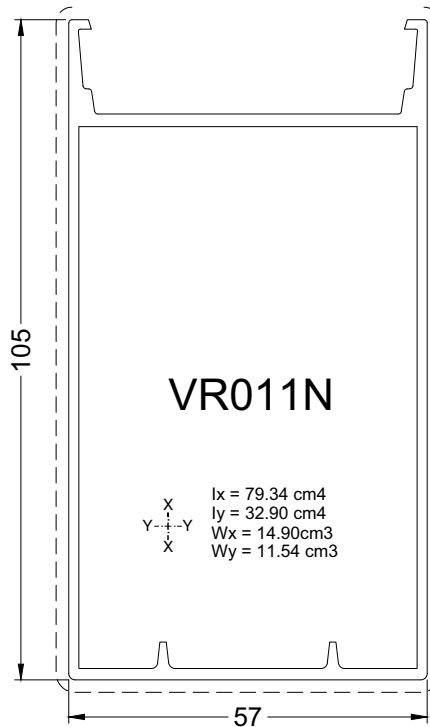

CRa04

MUURPROFIELEN
 PROFILS MURAL
 MAUERPROFIELEN
 WALLPROFILES

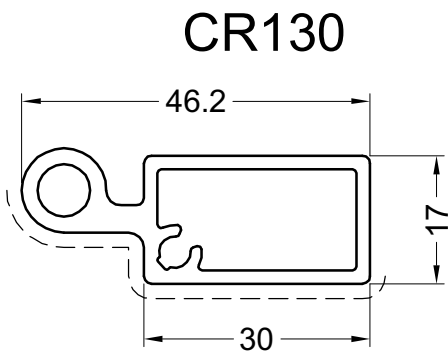
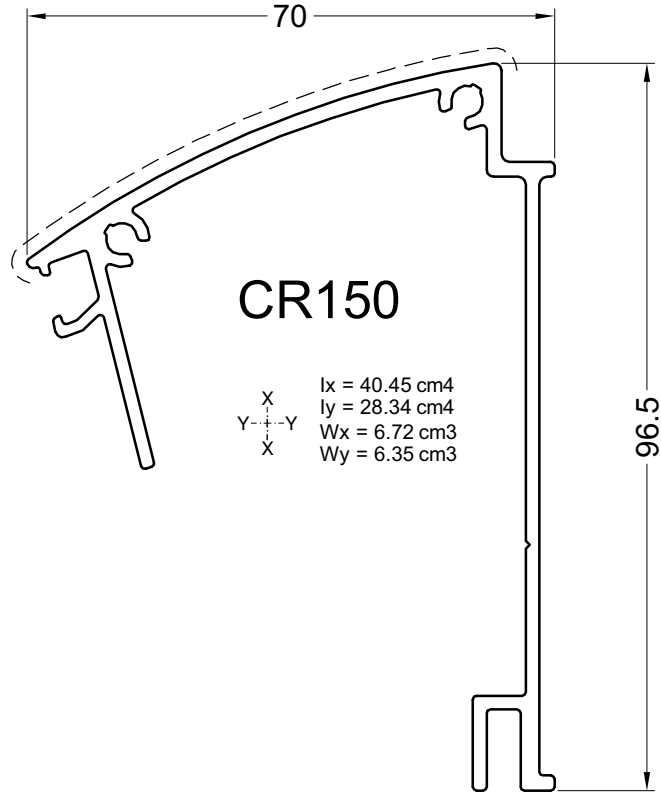

$I_x = 0.86 \text{ cm}^4$
 $I_y = 4.98 \text{ cm}^4$
 $W_x = 0.93 \text{ cm}^3$
 $W_y = 2.12 \text{ cm}^3$

CRa05

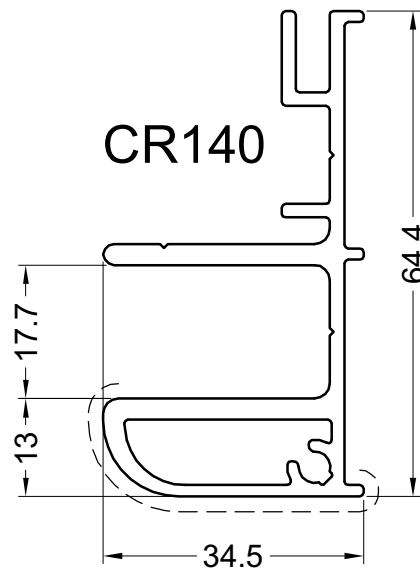

$I_x = 14.68 \text{ cm}^4$
 $I_y = 4.46 \text{ cm}^4$
 $W_x = 3.73 \text{ cm}^3$
 $W_y = 2.08 \text{ cm}^3$

Primaire zichtbare zijde
 Face visible primaire

Secundaire zichtbare zijde
 Face visible secondaire

KAP EN PAAL PROFIEL
 CAPOT ET POTEAU PROFILE
 KAP UND PFAHL PROFIL
 COVER AND POST PROFILE

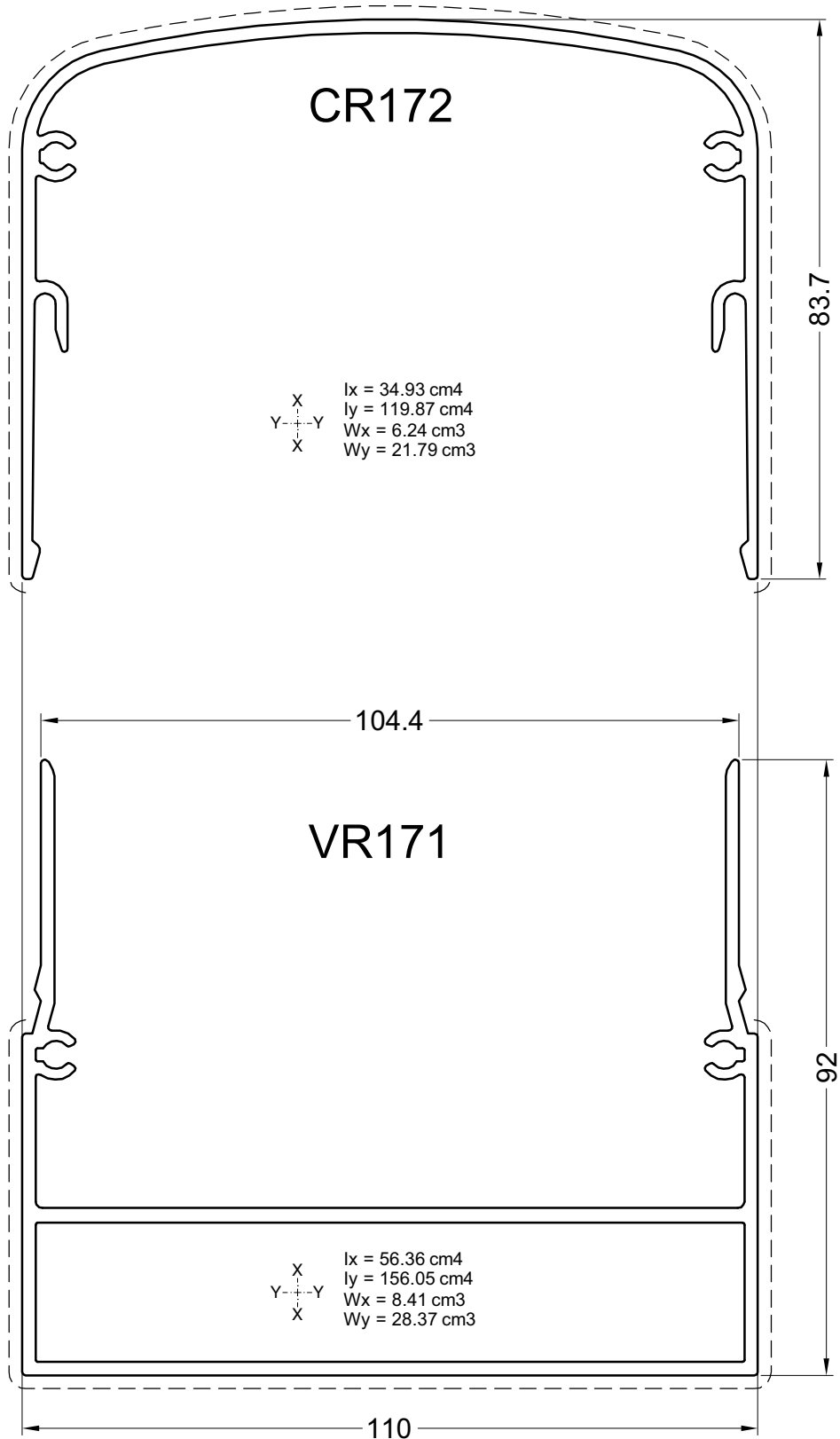

CRA06

ALU AFDEKKLIPS
 CLIPS EN ALU
 ALU KLIPSE
 ALU GLAZING CAPS

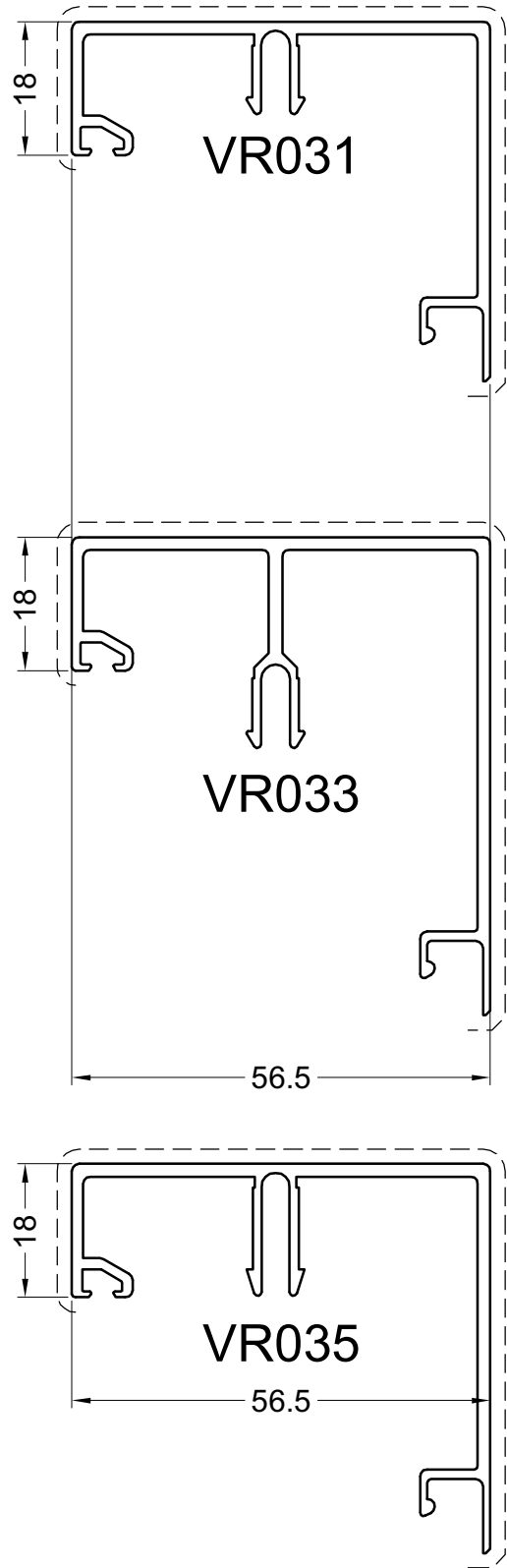
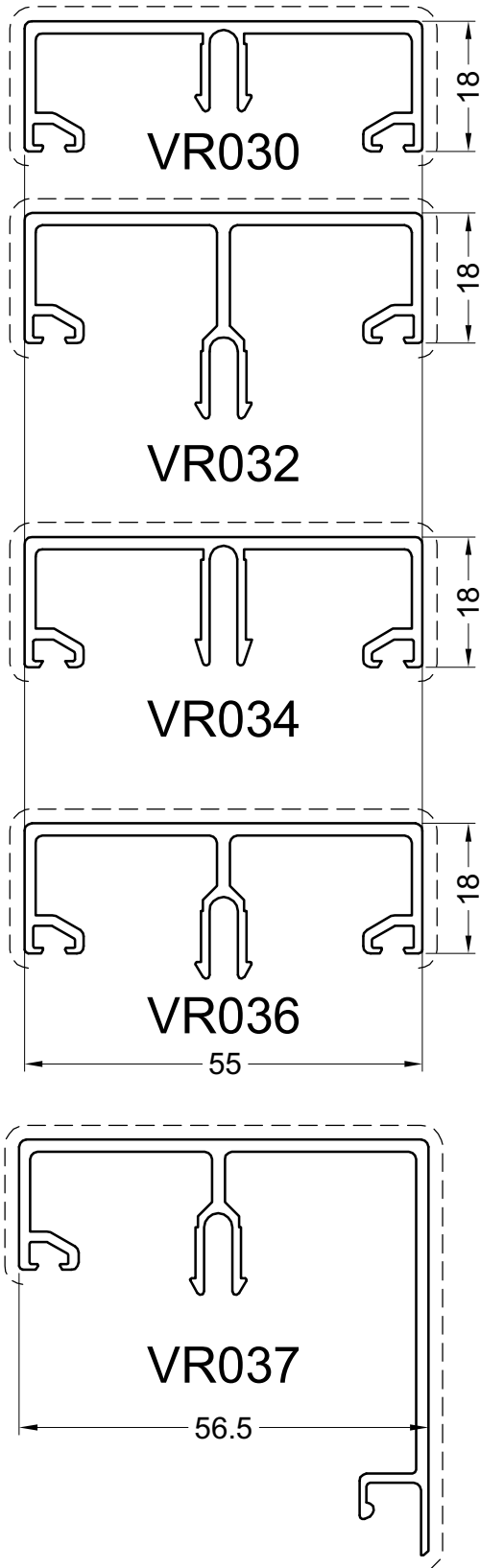

PROFIELEN - PROFILS - PROFILE - PROFILES

CRa07

POLYCARBONAATPROFIELEN
PROFILS POLYCARBONAT
FALZLEISTENPROFIELEN
POLYCARBONATE PROFILES

VR040

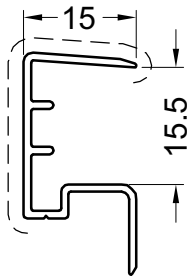

VR043

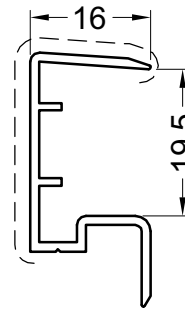

VR044

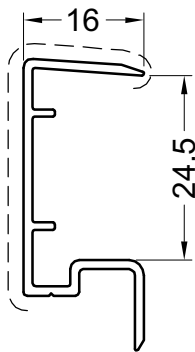

VR041

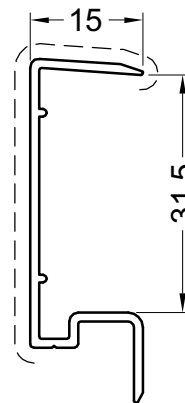

CRa08

PVC KLIPS VOOR POLYCARBONAAT
 CLIPS PVC POUR POLYCARBONAT
 PVC KLIPSE FÜR POLYCARBONAT
 PVC PROFILE FOR POLYCARBONATE

VR515a

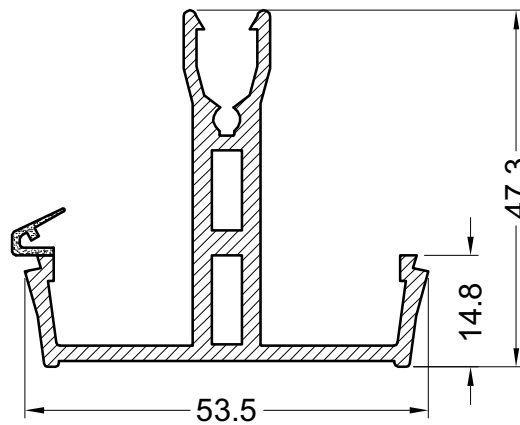

VR515

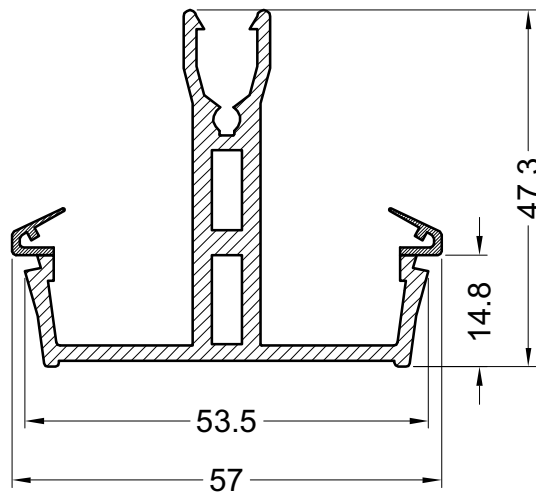

CRa09



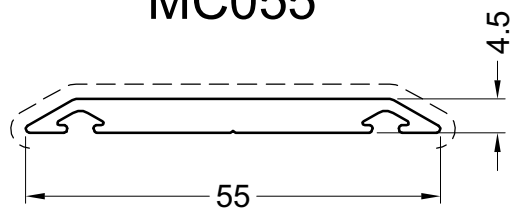

GLASVERDELINGSPROFIELEN
PROFILS POUR REPARTION VERRE
PROFILEN FÜR GLASVERTEILUNG
PROFILES FOR GLASSDIVISION



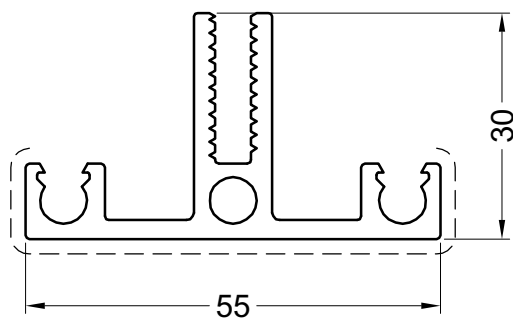

MC055









VR2030





		Toepassing Application Anwendung Application	Verp. per Emb. par Pack pr. Pack pr.
	ACCRI01 -Eindplaat voor CR100 -Plaque pour CR100 -Endstück für CR100 -Endpiece for CR100	CR100	1
	ACCRI02 -Eindplaat voor CR100 - CR105 -Plaque pour CR100 - CR105 -Endstück für CR100 - CR105 -Endpiece for CR100 - CR105	CR100 CR105	1
	ACCRI03 -Koppelstuk goot -Pièce raccord gouttière -Verbindingsstück Dachrinne -Coupling piece for gutter	CR100	1
	ACCRI05 -Eindplaat voor CR100 - CR105 - CR111 -Plaque pour CR100 - CR105 - CR111 -Endstück für CR100 - CR105 - CR111 -Endpiece for CR100 - CR105 - CR111	CR100 CR105 CR111	1
	ACCRI06 -Eindplaat voor CR100 - VR2725 - CR111 -Plaque pour CR100 - VR2725 - CR111 -Endstück für CR100 - VR2725 - CR111 -Endpiece for CR100 - VR2725 - CR111	CR100 VR2725 CR111	1

		Toepassing Application Anwendung	Verp. per Emb. par Pack pr. Pack pr.
	<p>ACCRI10</p> <ul style="list-style-type: none"> -Eindstuk ligger -Embout chevron -Endstück trager -End piece roof beam 	CR120	...
	<p>ACCRIII</p> <ul style="list-style-type: none"> -Fixatie verbinding scharnierprofiel -Fixation raccord profil charnière -Fixation verbinding scharnierprofiel -Fixation connecting hinge profile 	CR110	...
	<p>ACCRII2</p> <ul style="list-style-type: none"> -Afdichtingsrubber -Joint d'étancheite -Dichtungsgummi -Weathering gasket 	CR110	50M
	<p>ACCRI40</p> <ul style="list-style-type: none"> -Fixatie verbinding ligger -Fixation raccord chevron -Fixation verbinding trager -Fixation connecting roof beam 	CR140	...
	<p>ACCRI4I</p> <ul style="list-style-type: none"> -Fixatie verbinding ligger -Fixation raccord chevron -Fixation verbinding trager -Fixation connecting roof beam 	CR140	...

		Toepassing Application Anwendung Application	Verp. per Emb. par Pack pr. Pack pr.
	<p>ACCR150</p> <ul style="list-style-type: none"> -Eindplaat voor CR130 - CR140 - CR150 -Plaque pour CR130 - CR140 - CR150 -Endstück für CR130 - CR140 - CR150 -Endpiece for CR130 - CR140 - CR150 	<p>CR130 CR140 CR150</p>	<p>1</p>
	<p>ACCR250</p> <ul style="list-style-type: none"> -Eindplaat voor CR130 - CR140 - CR150 -Plaque pour CR130 - CR140 - CR150 -Endstück für CR130 - CR140 - CR150 -Endpiece for CR130 - CR140 - CR150 	<p>CR130 CR140 CR150</p>	<p>1</p>
	<p>ACCR322</p> <ul style="list-style-type: none"> -Verbindingsstuk goot en paal -Pièce de jonction gouttière et poteau -Verbindung traverse Dachrinne und pfahl -Binding joint gutter en post 	<p>VR171 CR171</p>	<p>1</p>
	<p>ACMC016</p> <ul style="list-style-type: none"> -Beglazingsrubber binnen 3mm -Joint de vitrage intérieur 3mm -Glasdichtung innen 3mm -Glazing gasket inside 3mm 	<p>CR110</p>	<p>150M</p>
	<p>ACMC109</p> <ul style="list-style-type: none"> -Schroef DIN7981 6,3x38 -Vis DIN7981 6,3x38 -Schraube DIN7981 6,3x38 -Screw DIN7981 6,3x38 	<p>MC055</p>	<p>200</p>

		Toepassing Application Application	Verp. per Emb. par Pack pr. Pack pr.
	ACMCIII -Afdichtingsring -Rondelle d'étanchéité -Dichtscheibe -Seilingring	ACMC109	100
	ACMCII7 -Beglazingsrubber -Joint -Fuge -Joint	MC055	50M
	ACMS02 -Dichting -Joint d'étanchéité -Abdichtungsgummi -Sealstrip	CR150	40M
	ACVRI71 -Verbindingsstuk goot en paal -Pièce de jonction gouttière et poteau -Verbindung traverse Dachrinne und pfahl -Binding joint gutter en post	CR100 VR171	1
	ACVR20I -Dichtingsstrip met lip -Joint d'étanchéité avec moustache -Abdichtungsgummi mit Lippe -Sealstrip with lip	VR030 VR031 VR032 VR033 VR034 VR035 VR036 VR037	100M

		Toepassing Application Anwendung Application	Verp. per Emb. par Pack pr. Pack pr.
	ACVR322 -Verbindingsstuk goot en paal -Pièce de jonction gouttière et poteau -Verbindung traverse Dachrinne und pfahl -Binding joint gutter en post	VR171 CR100	1
	ACVR516 -inbouwspot vast 220V - incl. lamp 50W -Spot encastrable fixe 220V - incl. lampe 50W -Einbau Spotlicht fest 220V - inkl Lampe 50W -Built-in spotlight fix 220V - incl lamp 50W Boor-Trou-Loch-Hole = diam. 49mm	CR100	1
	ACVR517 -inbouwspot wentelbaar 12V - incl. lamp 20W -Spot encastrable pivote 12V - incl. lampe 20W -Einbau Spotlicht beweglich 12V - inkl. Lampe 20W -Built-in pivot spotlight 12V - incl lamp 20W Boor-Trou-Loch-Hole = diam. 49mm	CR100	1
	ACVR1015 -Eindstuk 76mm -Pièce latérale 76mm -abdichtung 76mm -Sealing 76mm	VR030 VR031 VR032 VR033 VR034 VR035 VR036 VR037	1 10
	ACVR2015 -Eindstuk 91mm -Pièce latérale 91mm -abdichtung 91mm -Sealing 91mm	VR030 VR031 VR032 VR033 VR034 VR035 VR036 VR037	1 10

		Toepassing Application Anwendung Application	Verp. per Emb. par Pack pr. Pack pr.
	<p>ACVR2227</p> <ul style="list-style-type: none"> -Verbindingsstuk goot en paal -Pièce de jonction gouttière et poteau -Verbindung traverse Dachrinne und pfahl -Binding joint gutter en post 	<p>VR030 VR031 VR032 VR033 VR034 VR035 VR036 VR037</p>	<p>1</p>
	<p>ACVR2727</p> <ul style="list-style-type: none"> -EPDM spie -Cale EPDM -EPDM Keil -EPDM cotter 	<p>CR100 CR105</p>	<p>1</p>

STATICA LIGGER
 STATIQUE CHEVRON
 STATIK TRAGER
 STATICS ROOF BEAM

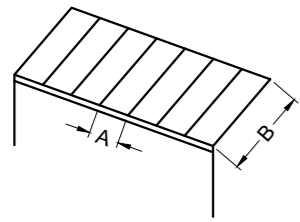

CR120
 $I_{xx} = 79.5085 \text{ cm}^4$

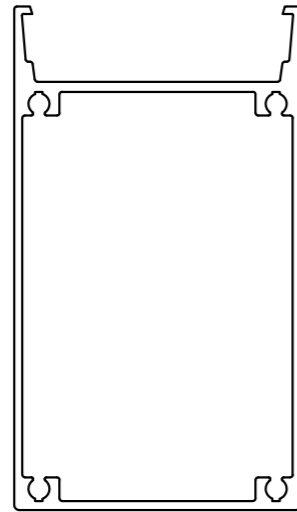

CR120 + Staal 70x50x4 mm
 $I_{xx} = 251.5789 \text{ cm}^4$

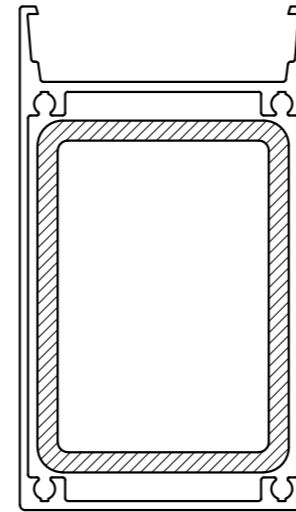

CR120 + CR126
 $I_{xx} = 187.9621 \text{ cm}^4$

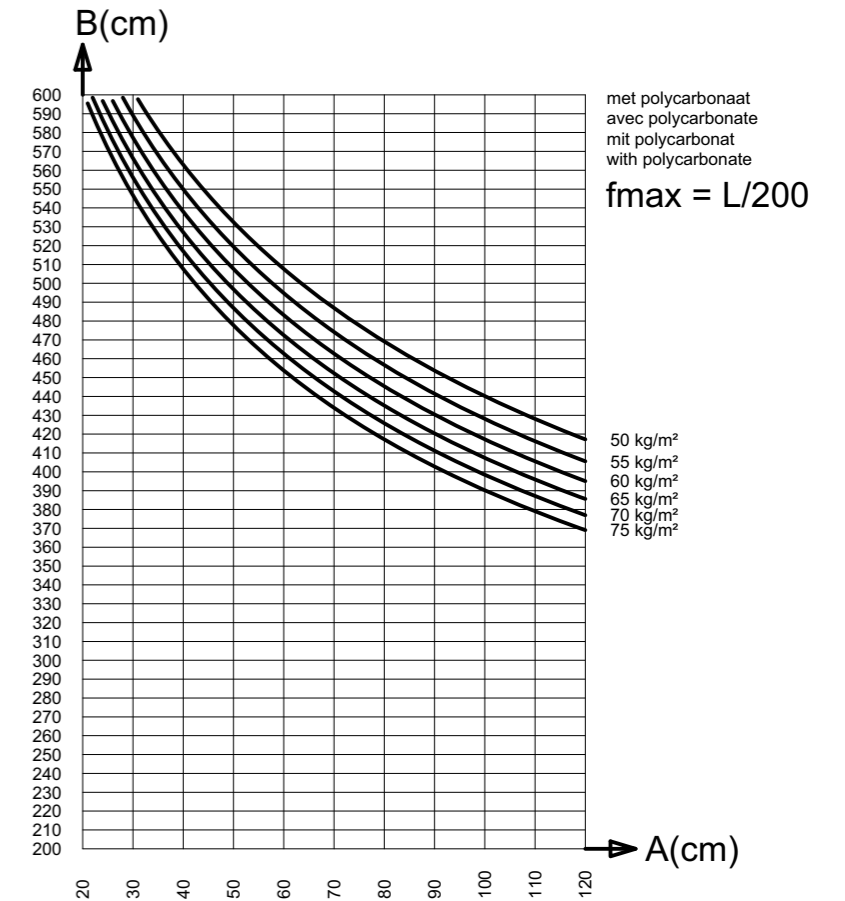
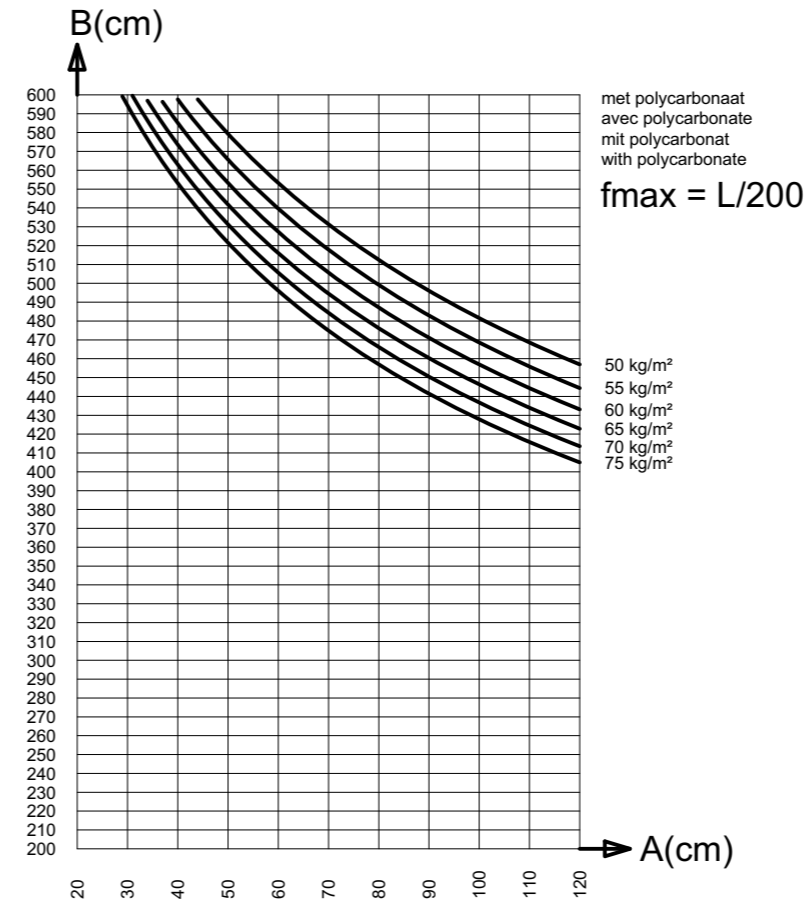
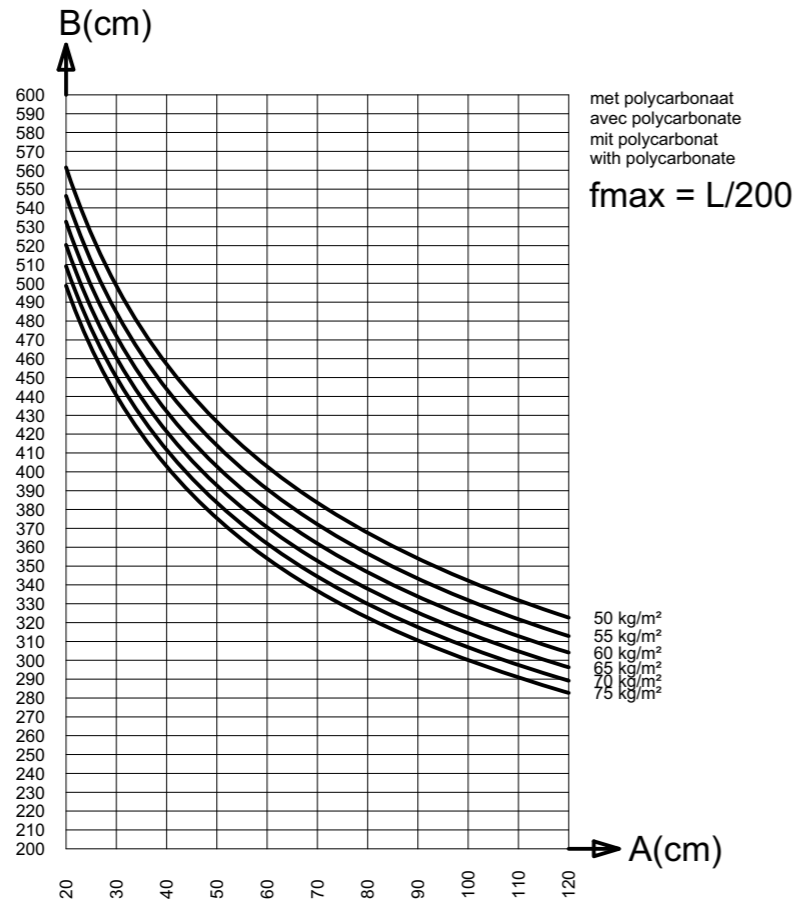
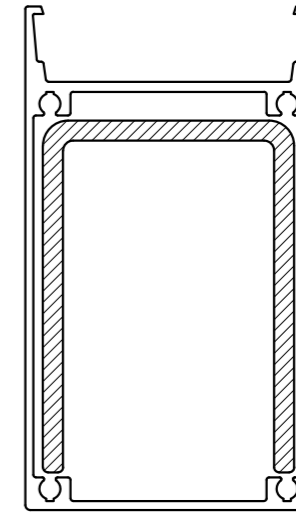

STATICA LIGGER
 STATIQUE CHEVRON
 STATIK TRAGER
 STATICS ROOF BEAM

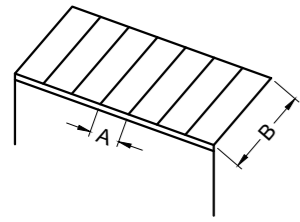

CR120
 $I_{xx} = 79.5085 \text{ cm}^4$

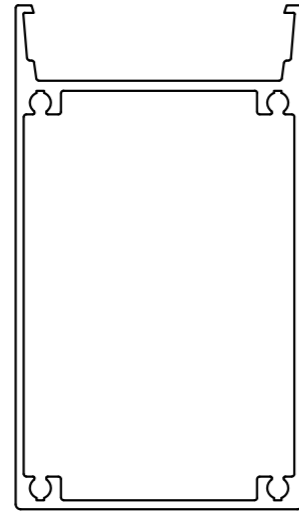

CR120 + Staal 70x50x4 mm
 $I_{xx} = 251.5789 \text{ cm}^4$

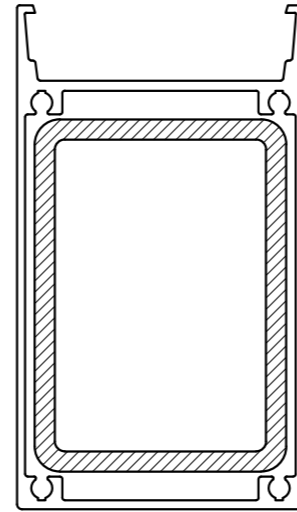

CR120 + CR126
 $I_{xx} = 187.9621 \text{ cm}^4$

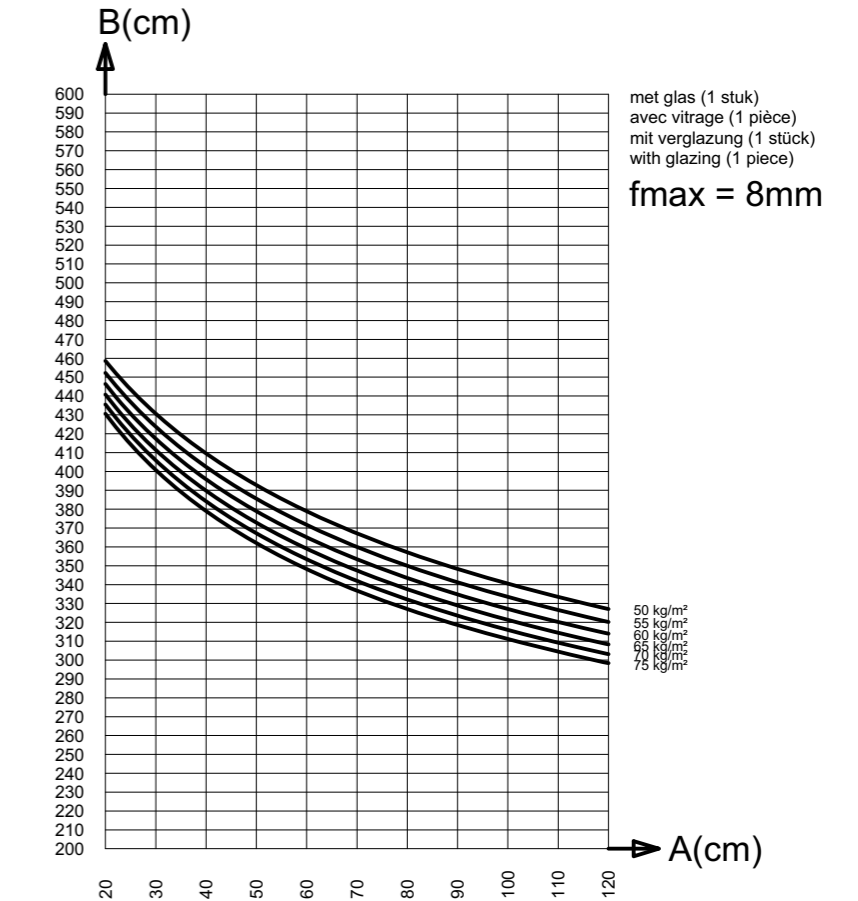
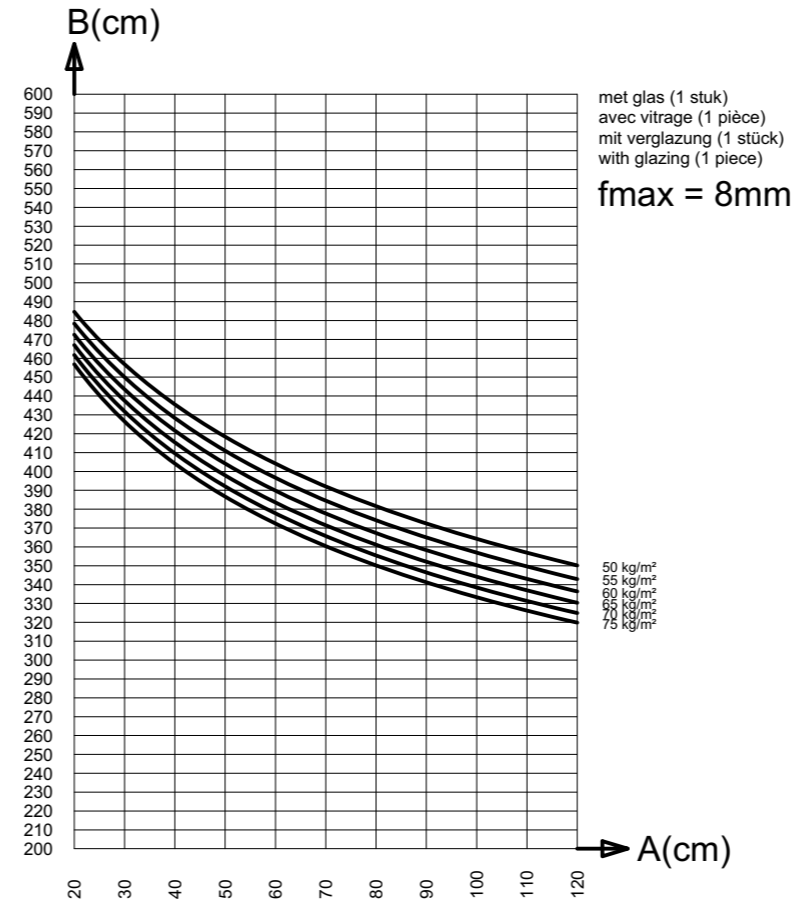
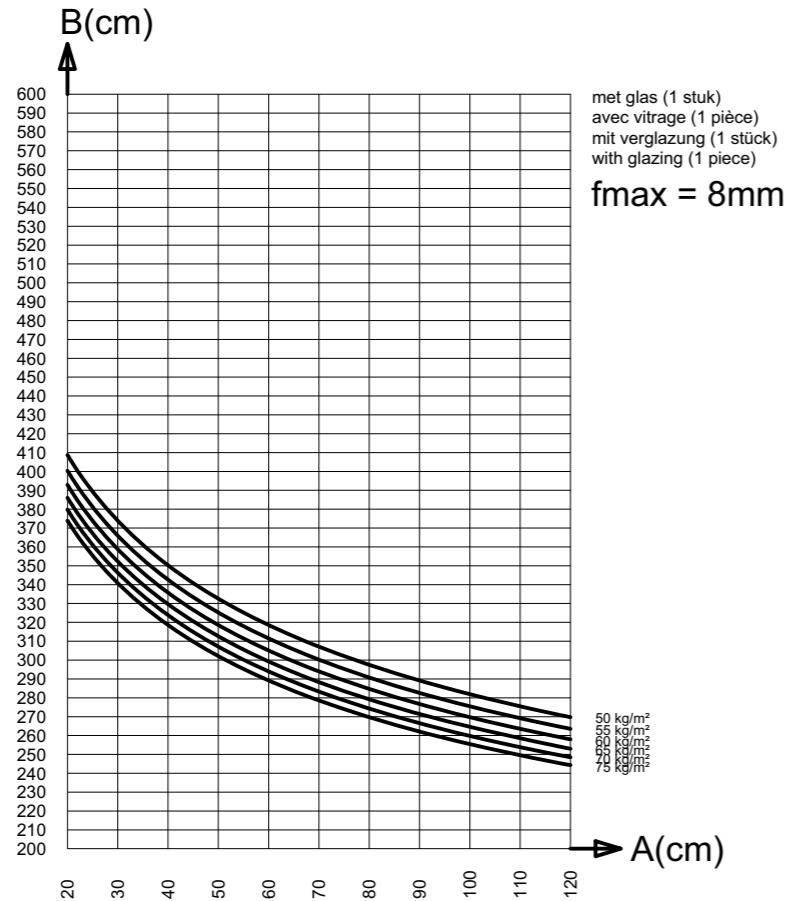
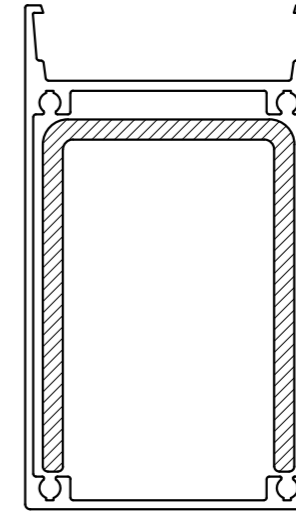

STATICA LIGGER
 STATIQUE CHEVRON
 STATIK TRAGER
 STATICS ROOF BEAM

CR120
 $I_{xx} = 79.5085 \text{ cm}^4$

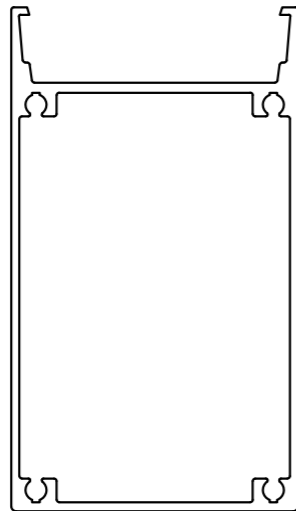
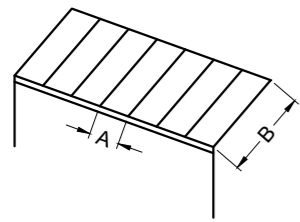

CR120 + Staal 70x50x4 mm
 $I_{xx} = 251.5789 \text{ cm}^4$

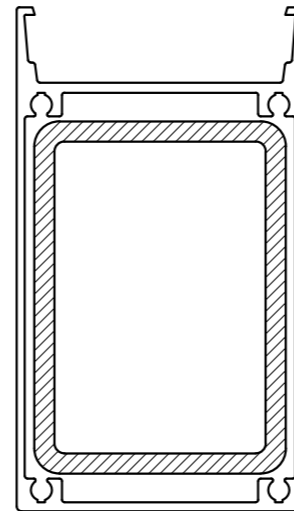

CR120 + CR126
 $I_{xx} = 187.9621 \text{ cm}^4$

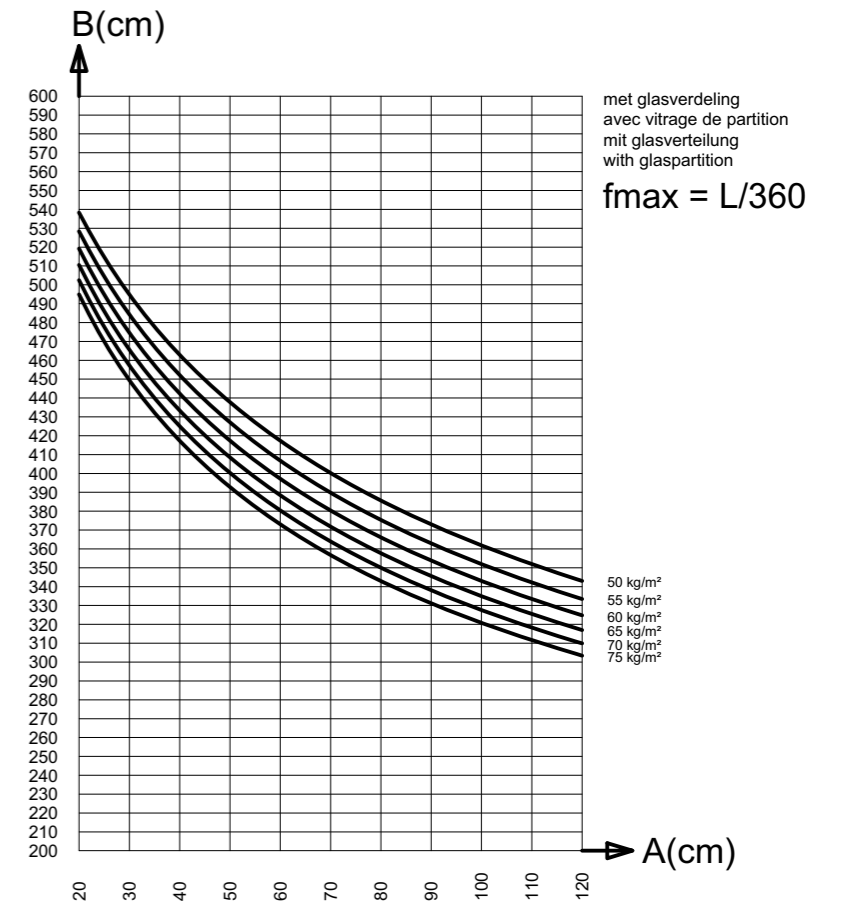
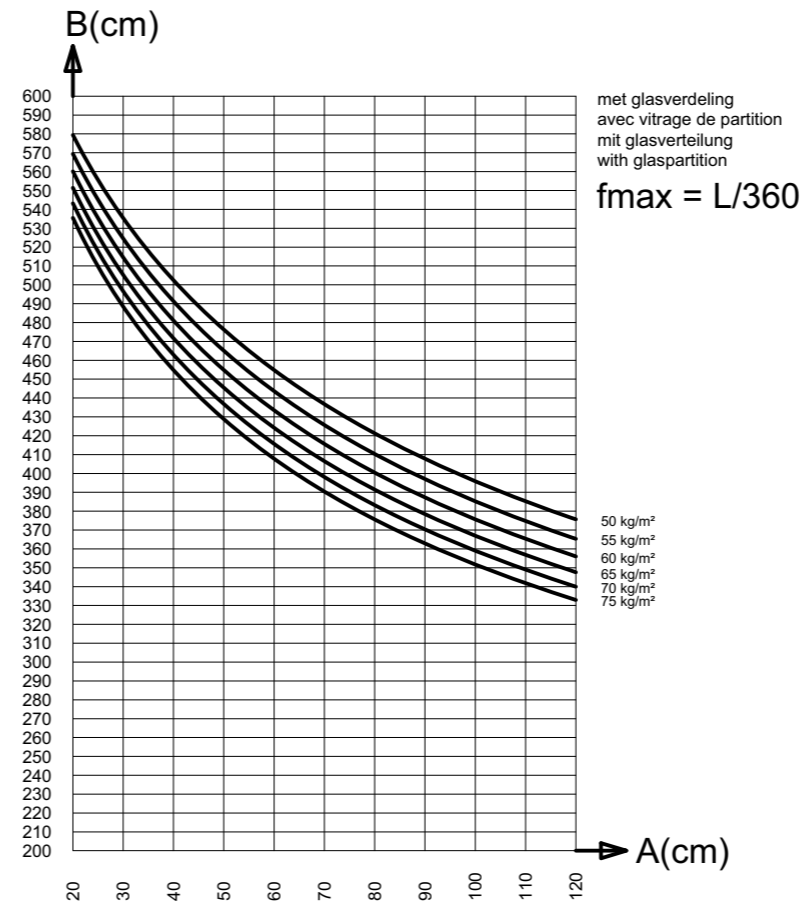
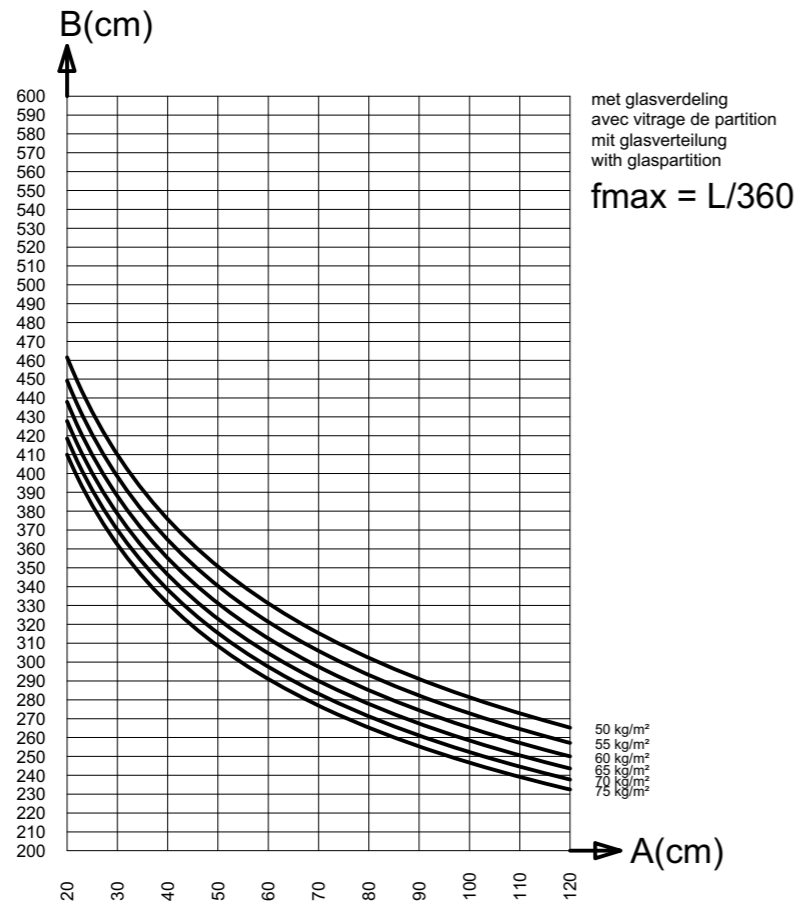
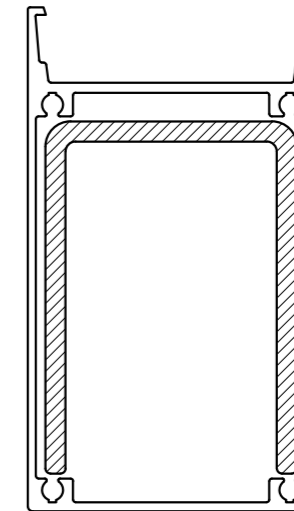

Statica_1c-1

STATICA GOOTPROFIEL
 STATIQUE GOUTTIERE
 STATIK DACHRINNE
 STATICS GUTTER PROFILE

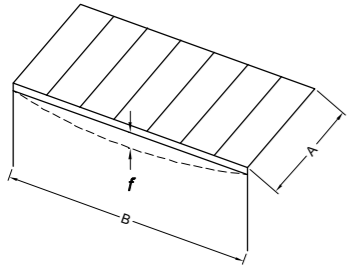

CR100 + CR110
 $I_{xx} = 107.1811 \text{ cm}^4$

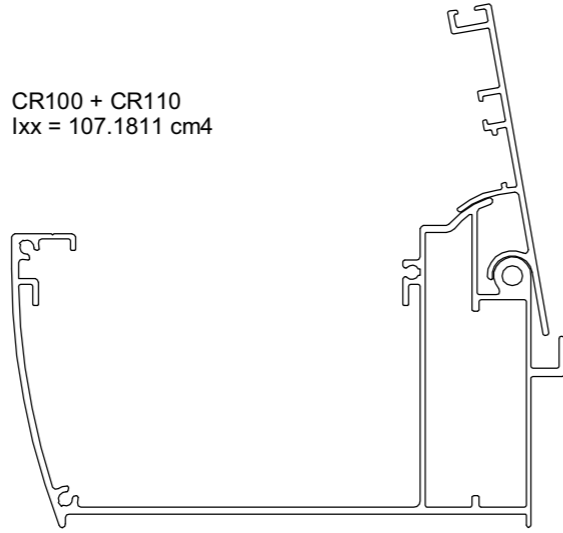

CR100 + CR110 + CR106 + CR108
 $I_{xx} = 348.855 \text{ cm}^4$

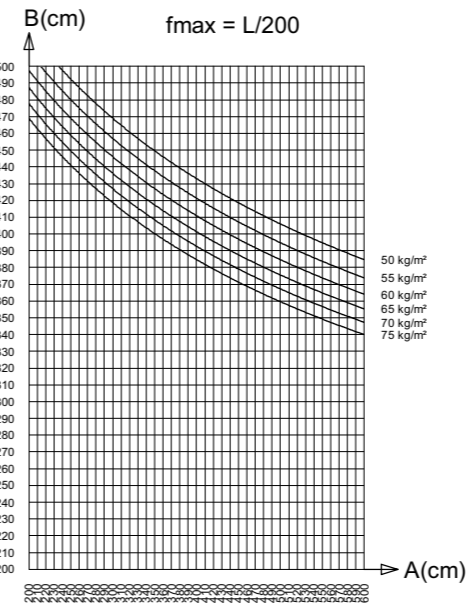
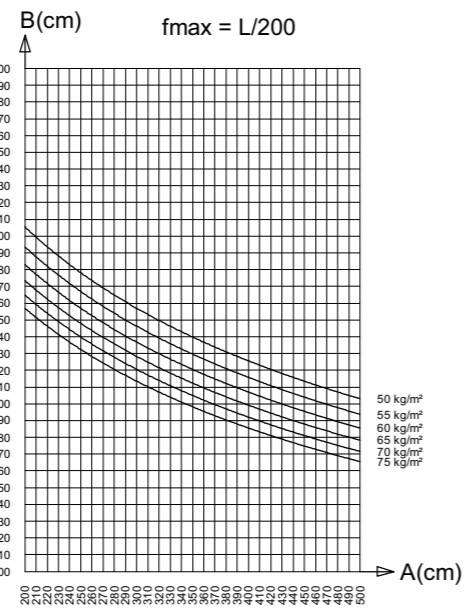
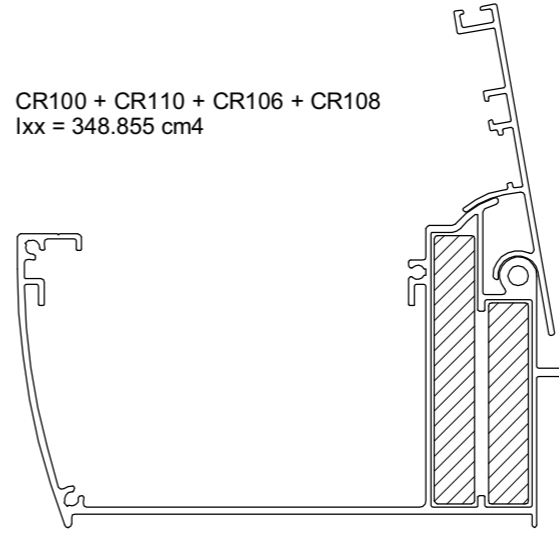

STATICA LIGGER
 STATIQUE CHEVRON
 STATIK TRAGER
 STATICS ROOF BEAM

CR220
 $I_{xx} = 253.1016 \text{ cm}^4$

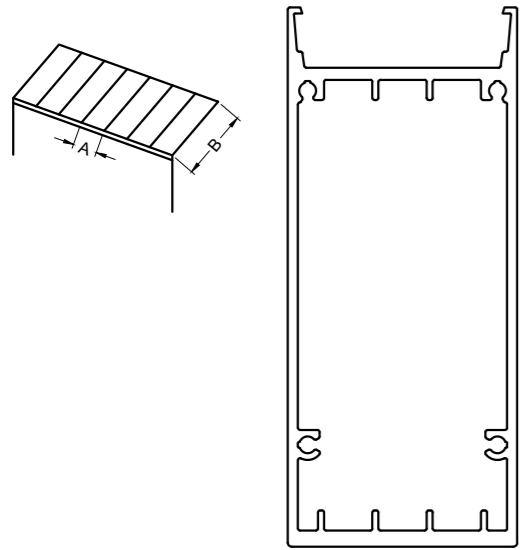

CR220 + CR226
 $I_{xx} = 446.1195 \text{ cm}^4$

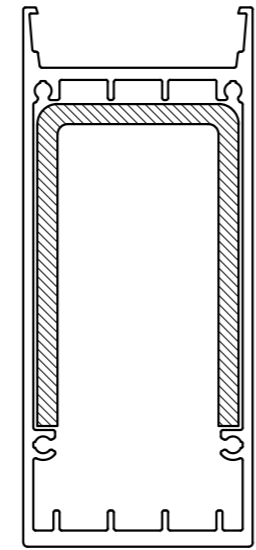

CR220 + VR063
 $I_{xx} = 773.3685 \text{ cm}^4$

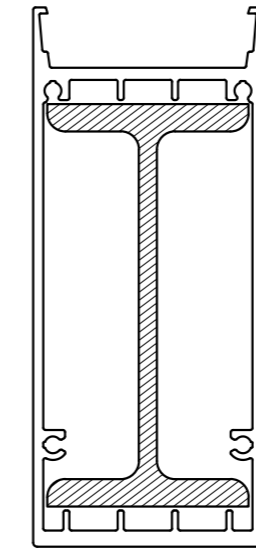

CR220 + 3x staal 110x10 mm
 $I_{xx} = 1249.0335 \text{ cm}^4$

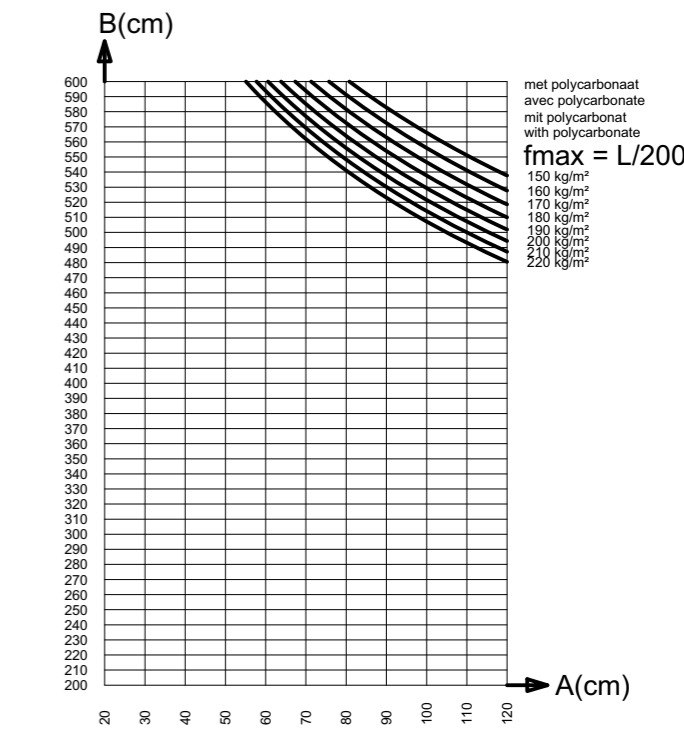
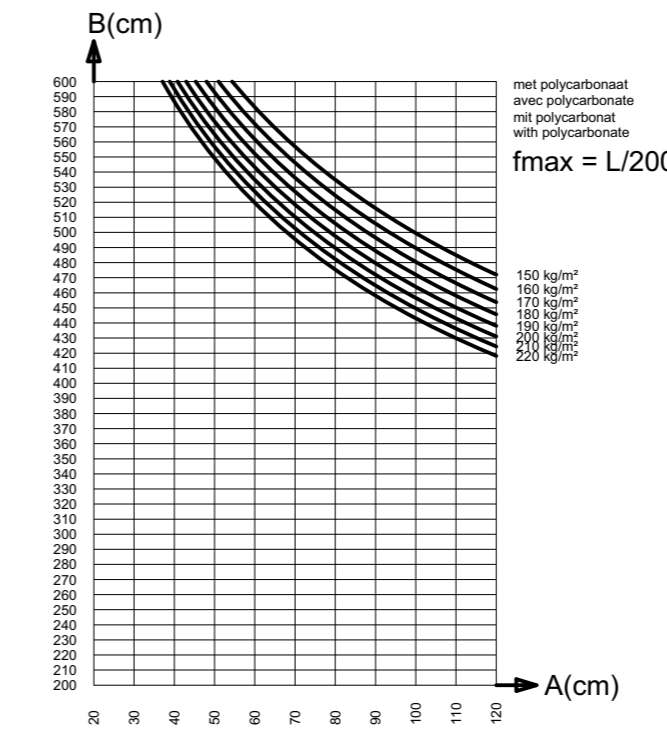
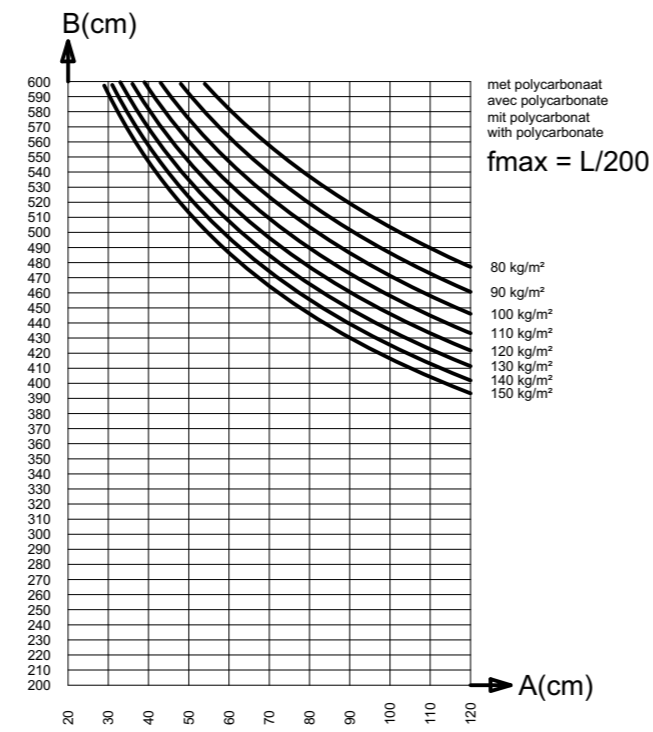
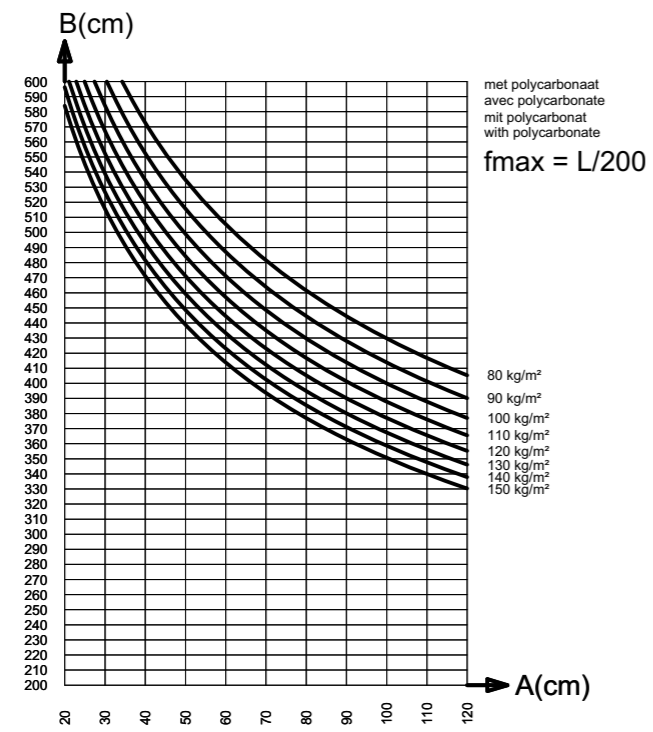
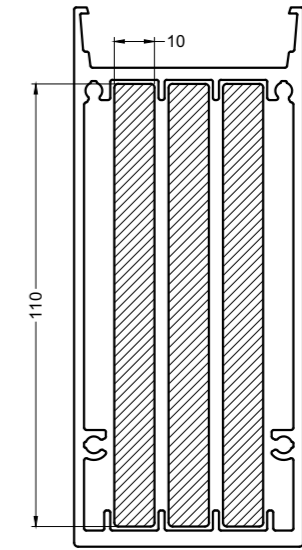

STATICA - STATIQUE - STATIK - STATICS

STATICA LIGGER
 STATIQUE CHEVRON
 STATIK TRAGER
 STATICS ROOF BEAM

CR220
 $I_{xx} = 253.1016 \text{ cm}^4$

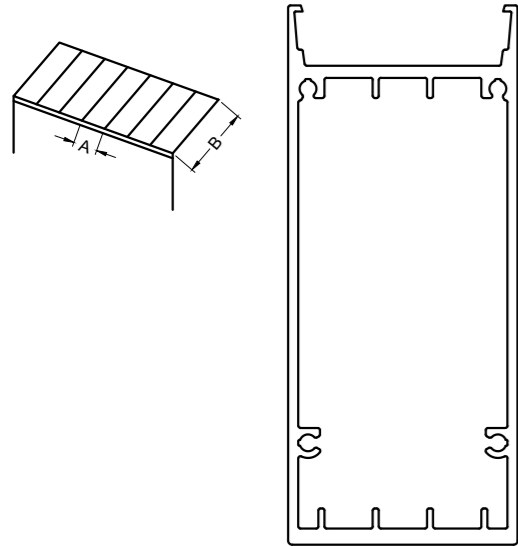

CR220 + CR226
 $I_{xx} = 446.1195 \text{ cm}^4$

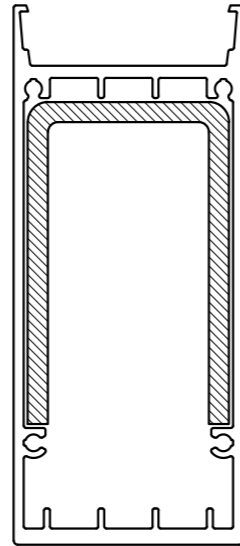

CR220 + VR063
 $I_{xx} = 773.3685 \text{ cm}^4$

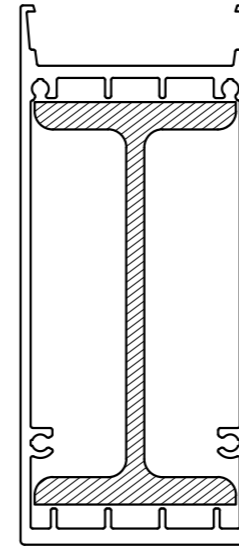

CR220 + 3x staal 110x10 mm
 $I_{xx} = 1249.0335 \text{ cm}^4$

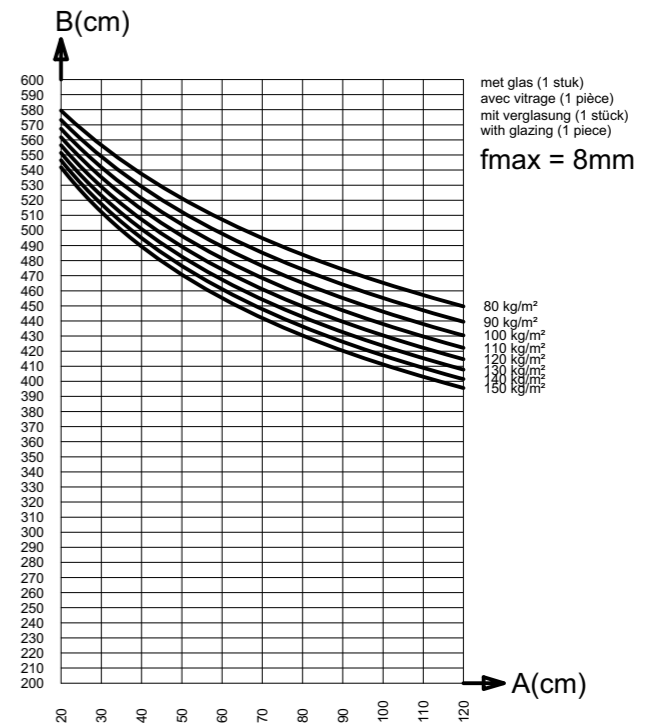
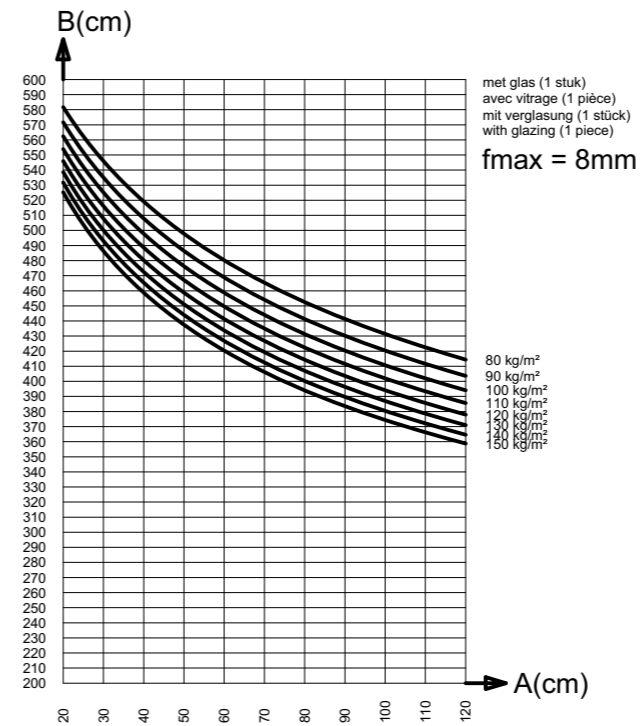
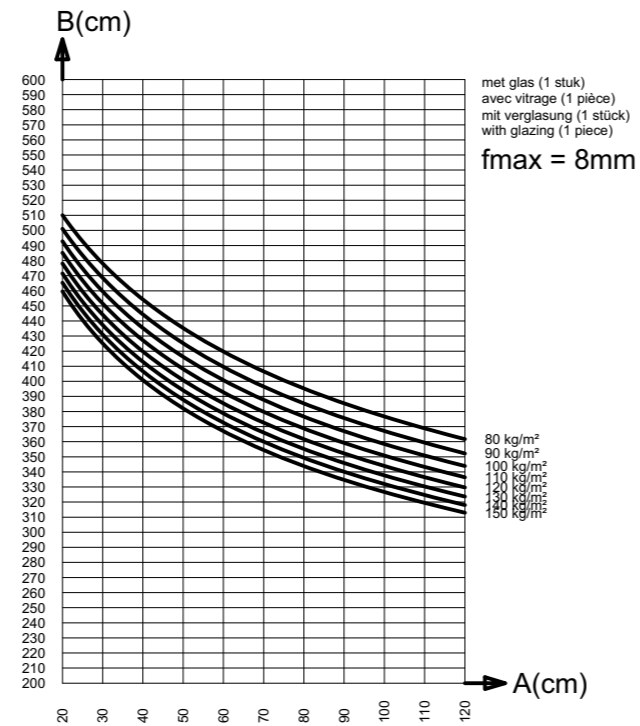
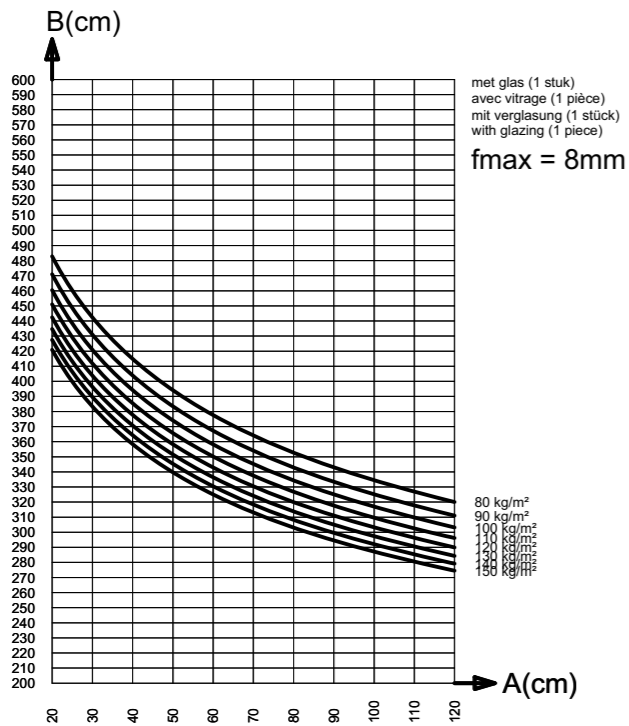
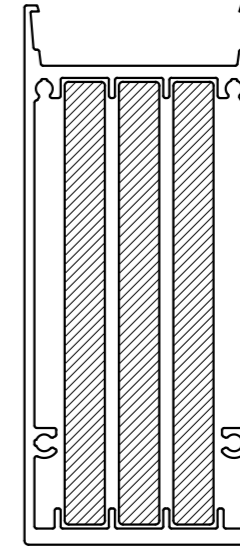

STATICA LIGGER
 STATIQUE CHEVRON
 STATIK TRAGER
 STATICS ROOF BEAM

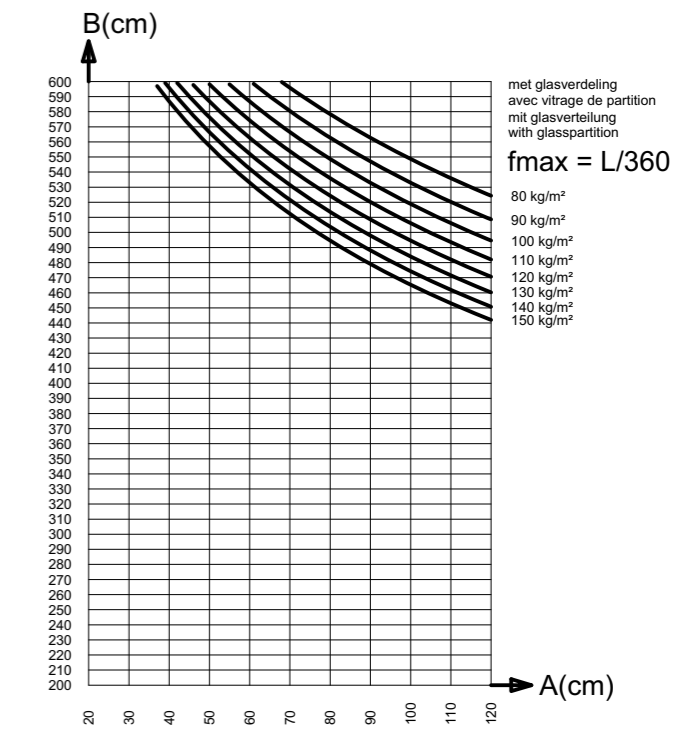
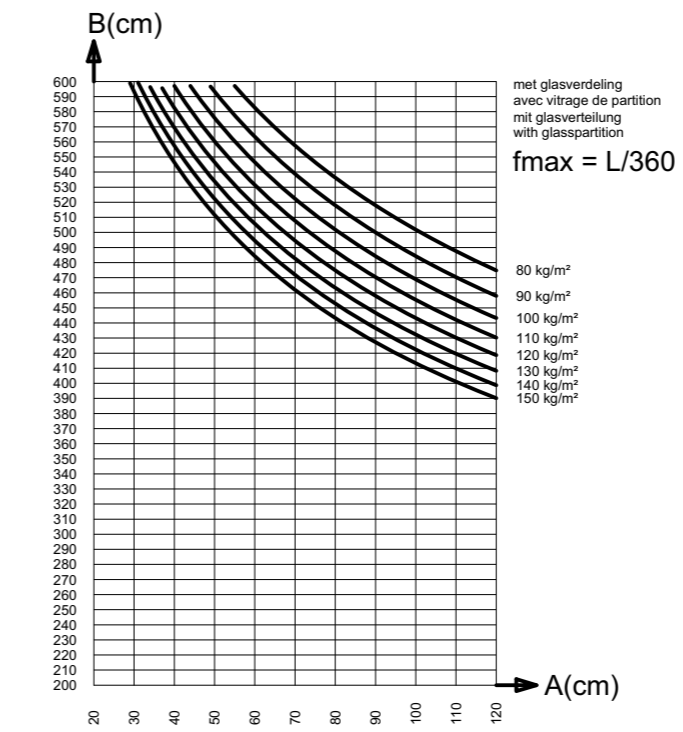
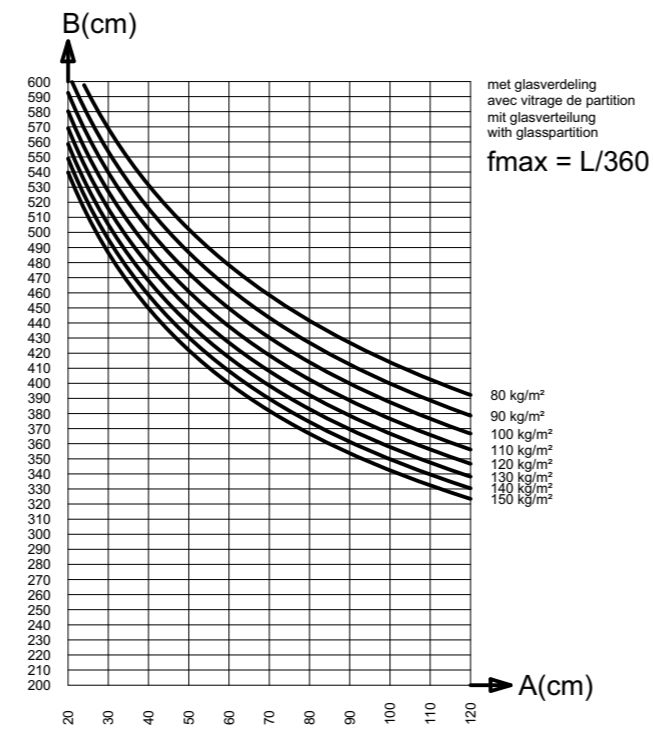
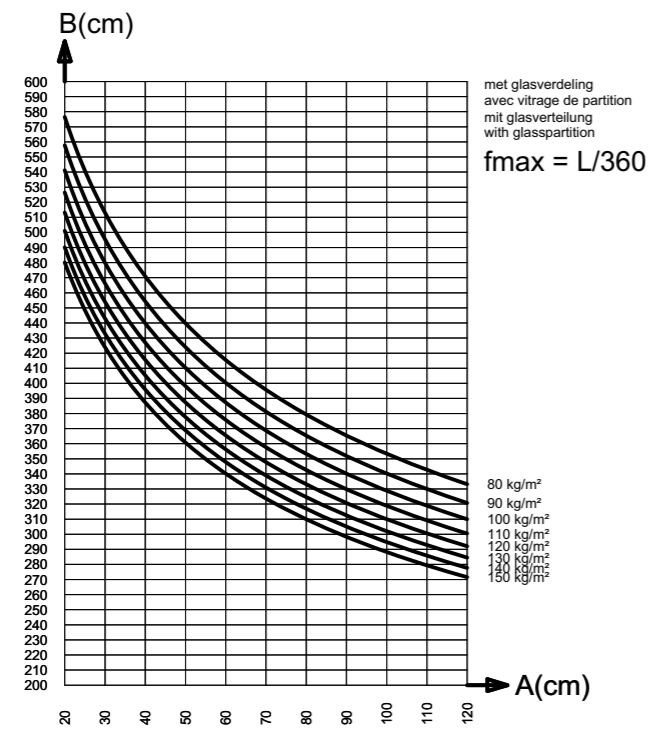
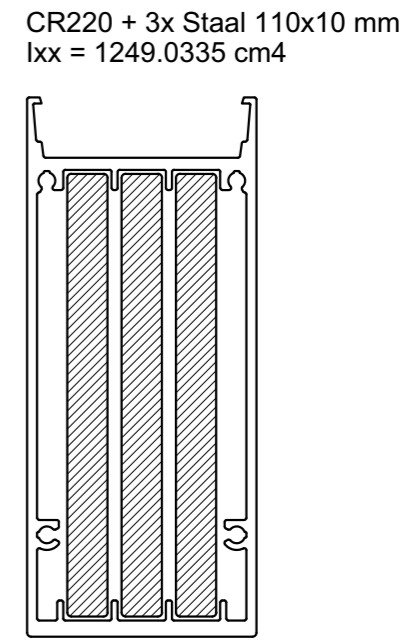
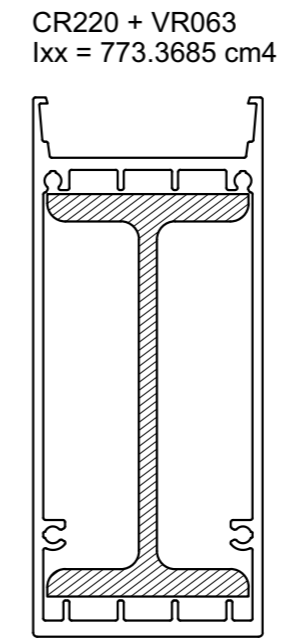
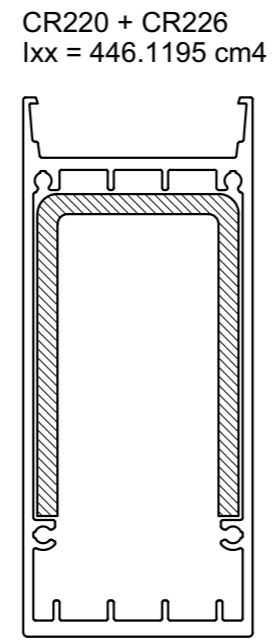
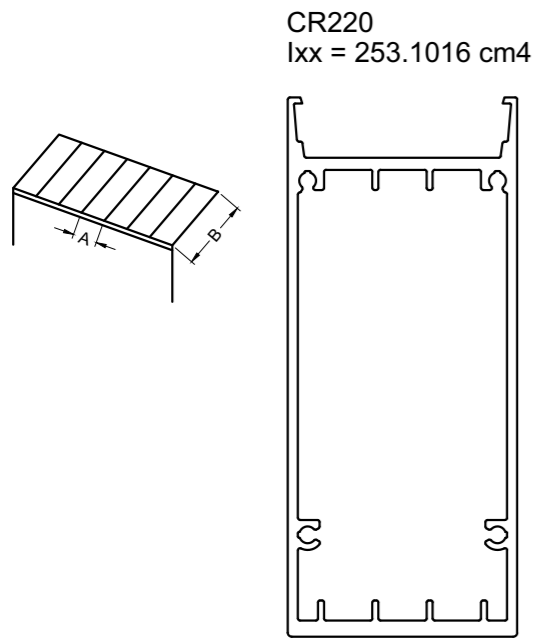

STATICA - STATIQUE - STATIK - STATICS

STATICA GOOTPROFIEL
 STATIQUE GOUTTIERE
 STATIK DACHRINNE
 STATICS GUTTER PROFILE

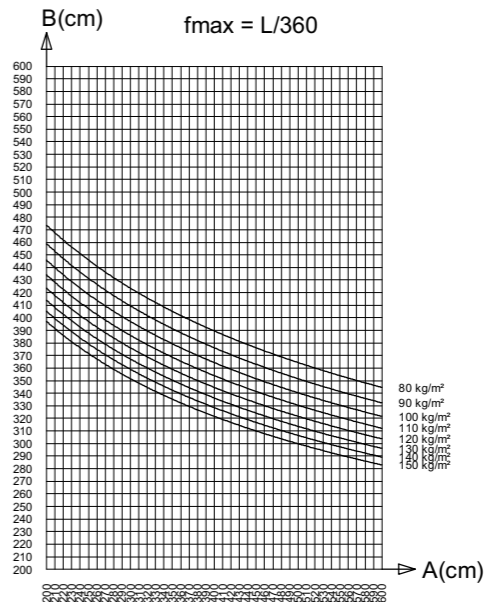
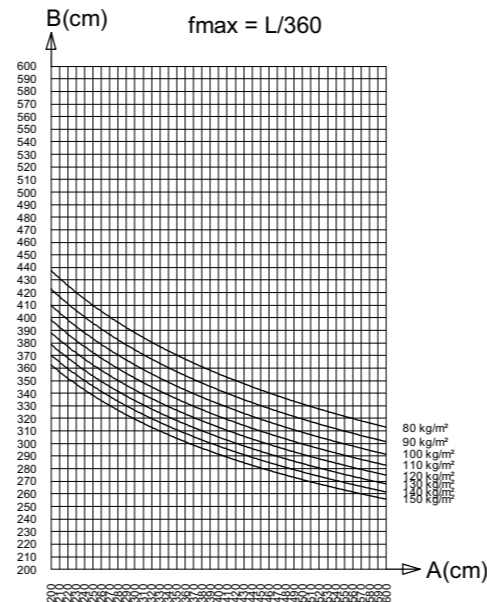
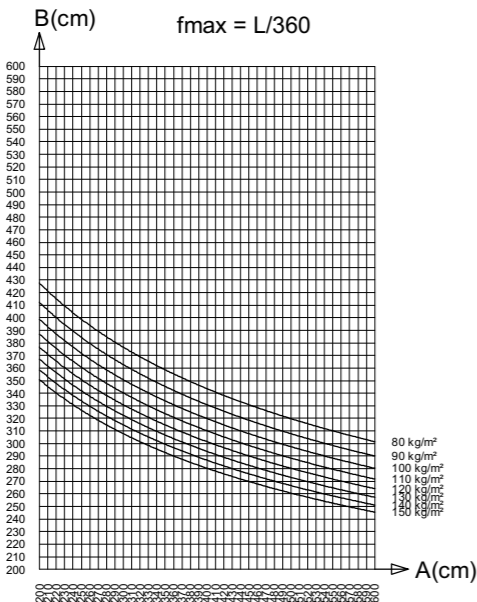
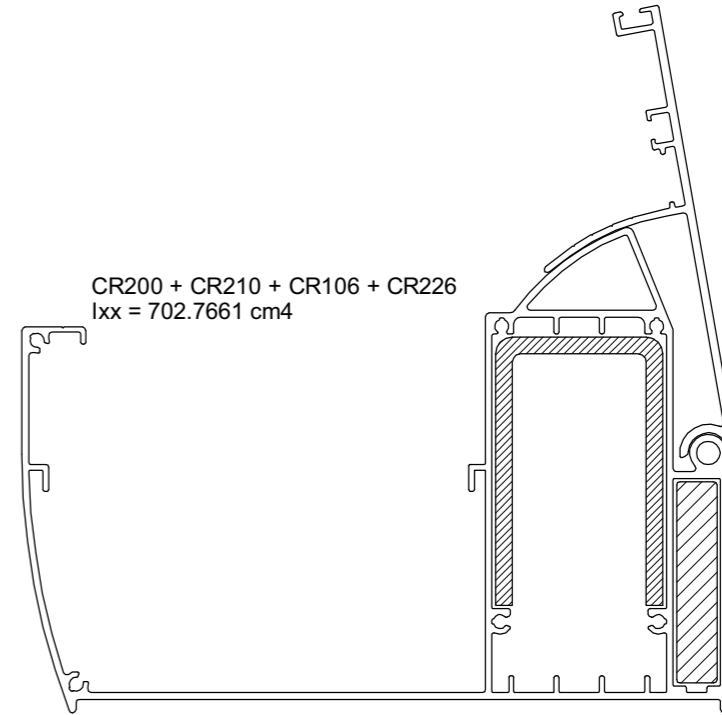
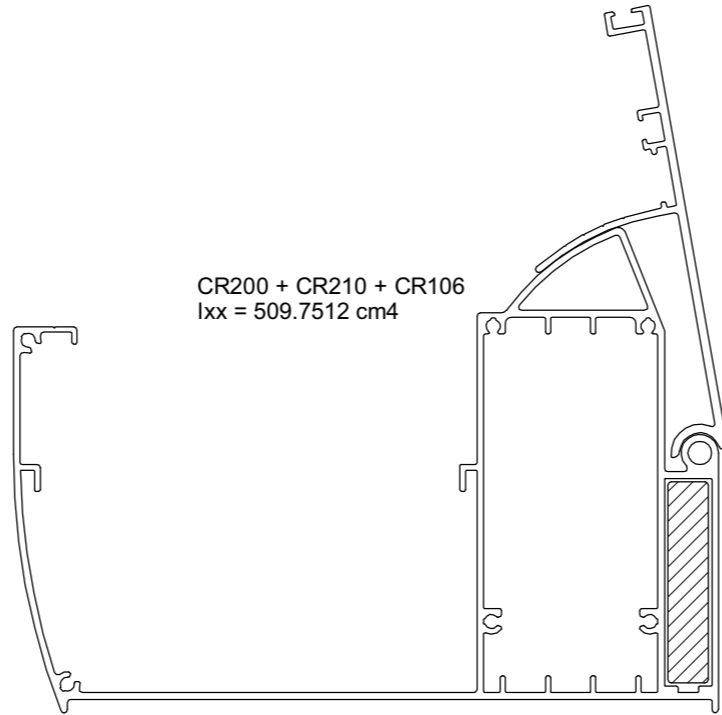
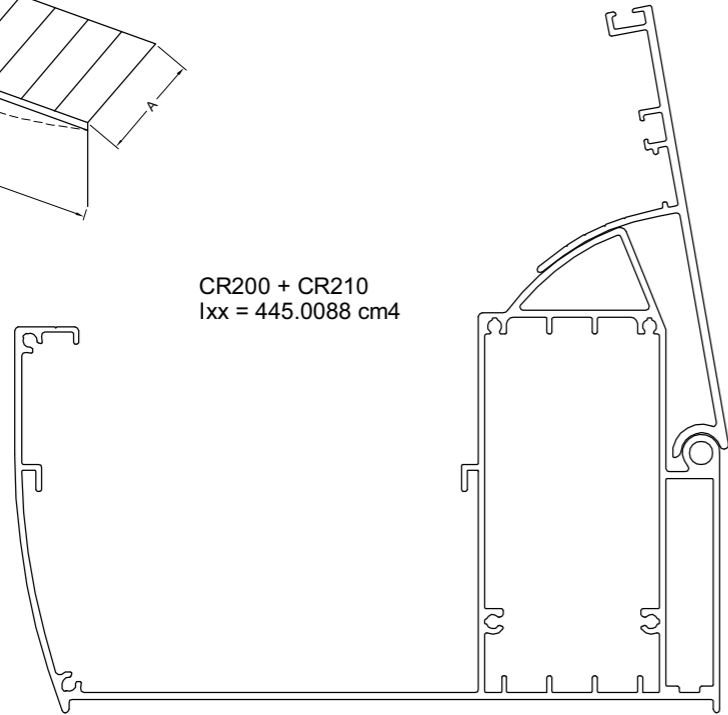
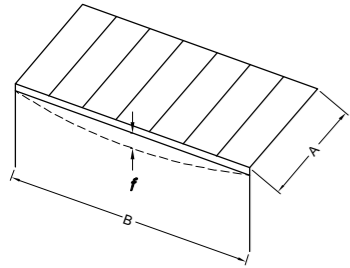

STATICA GOOTPROFIEL
 STATIQUE GOUTTIERE
 STATIK DACHRINNE
 STATICS GUTTER PROFILE

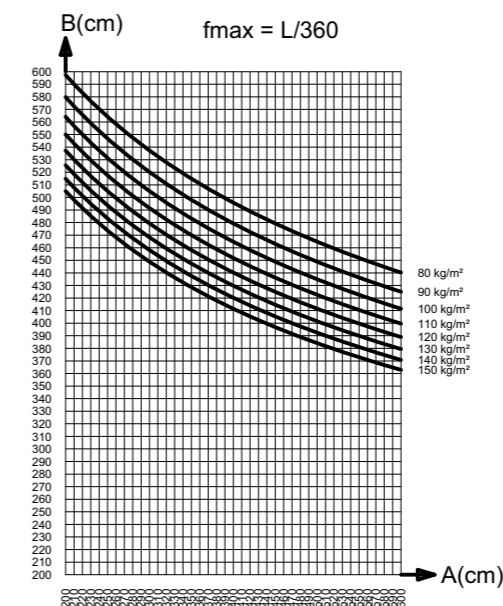
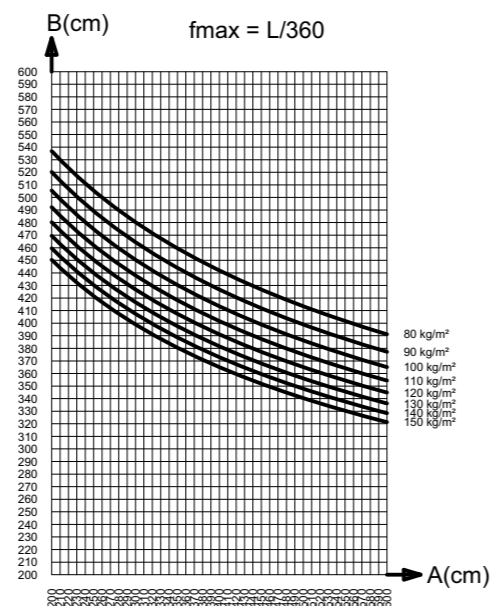
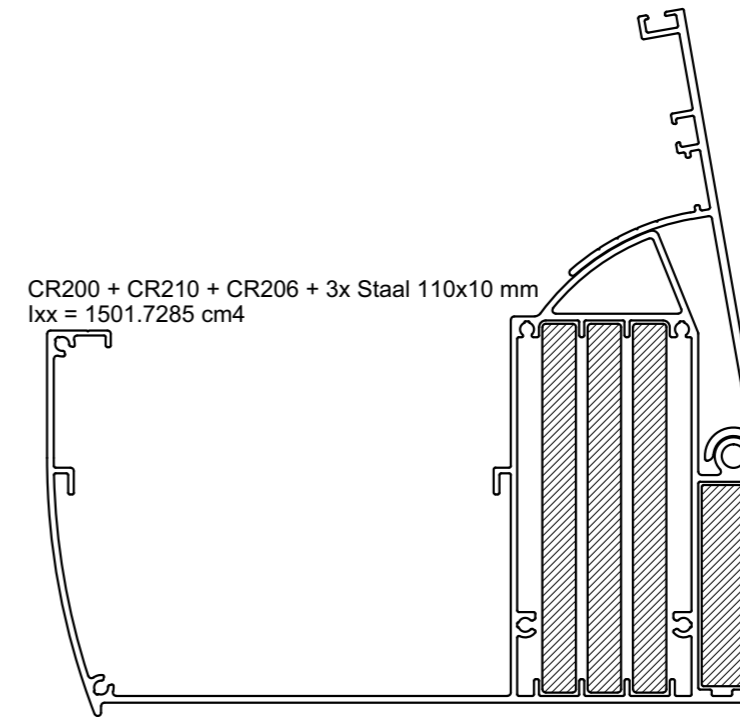
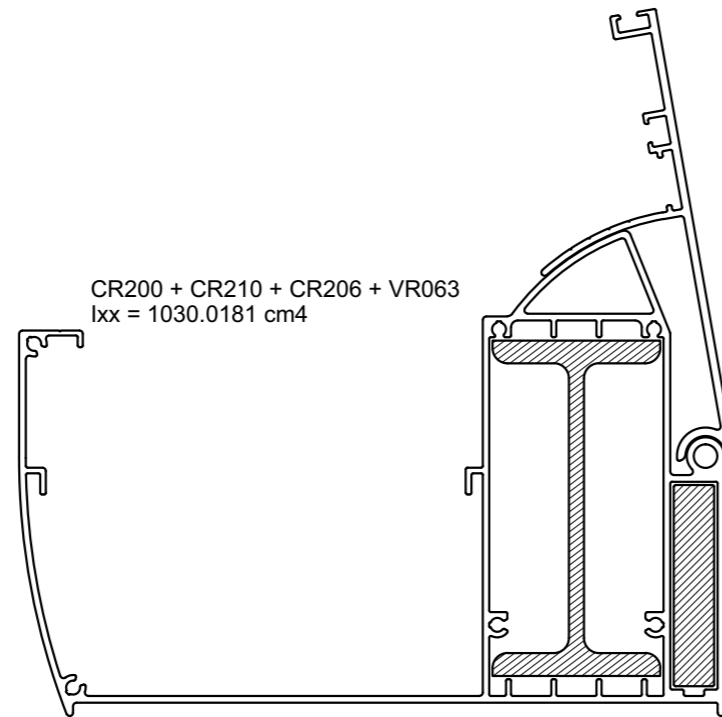
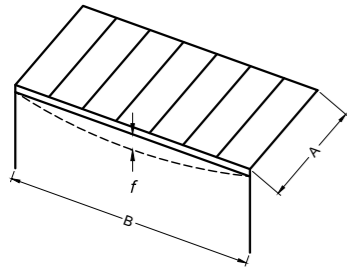

Statica_3



DOORSNEDES - COUPES - SCHNITT-SECTIONS

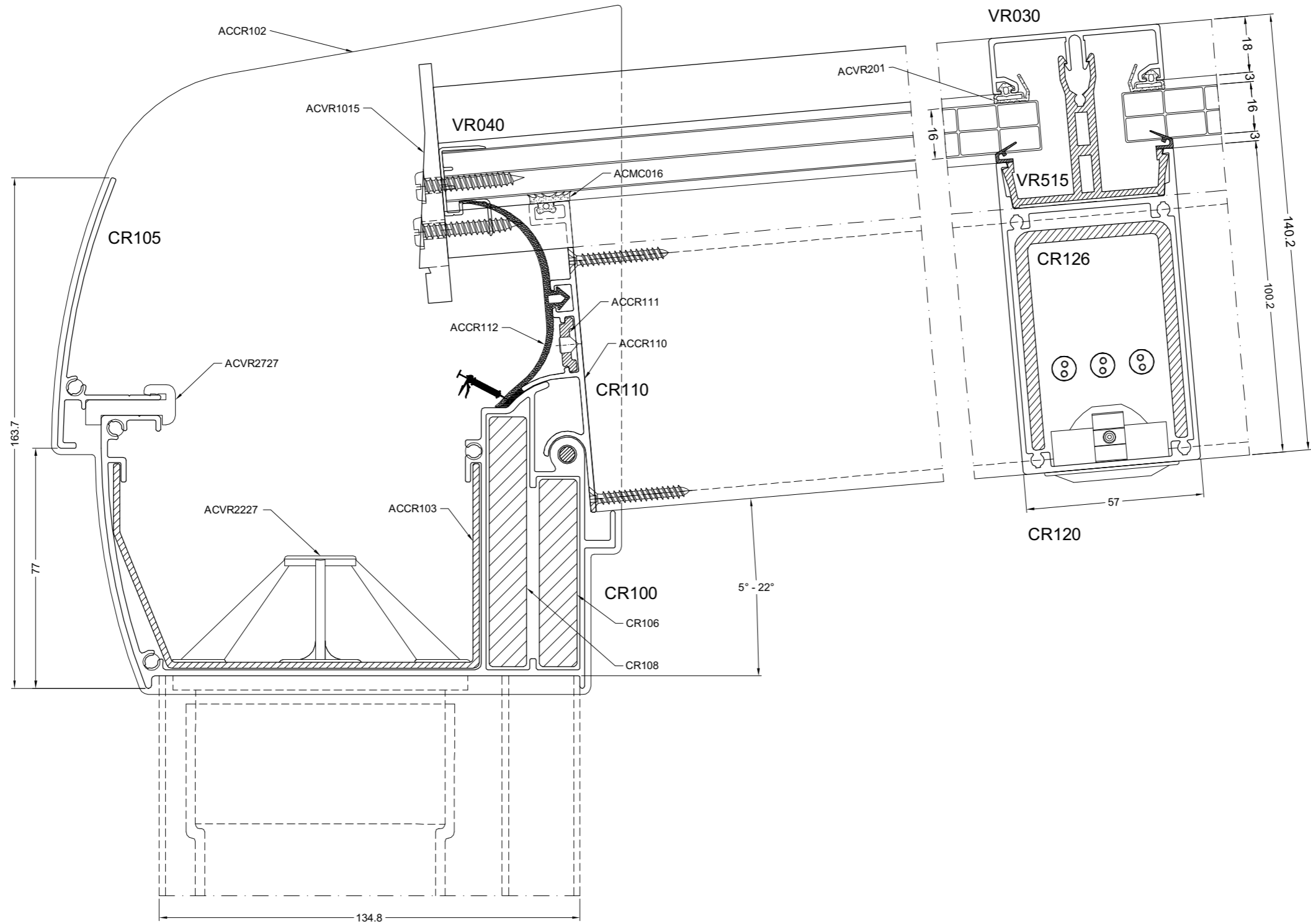

snede_1

1B

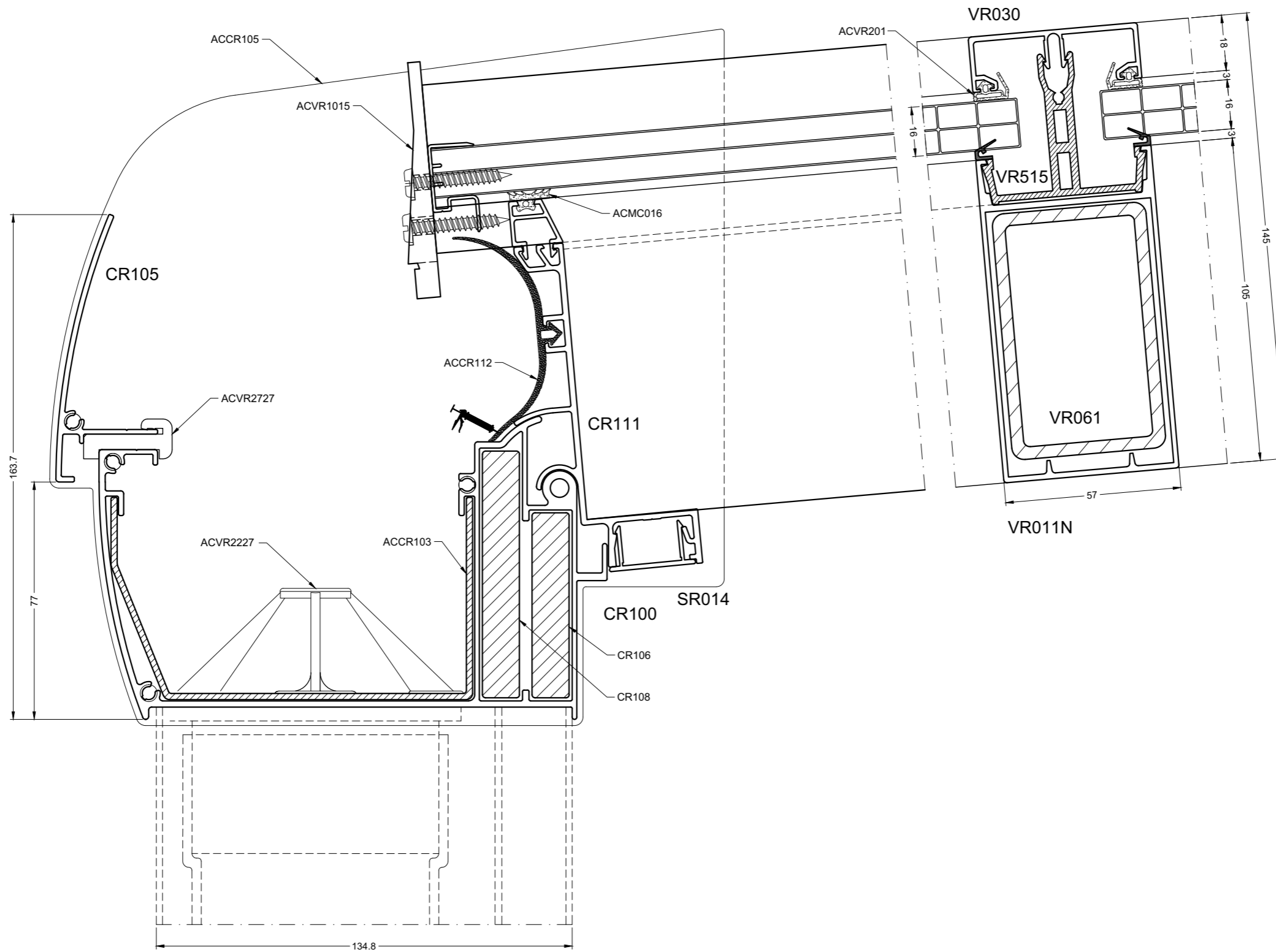

sneede_1B

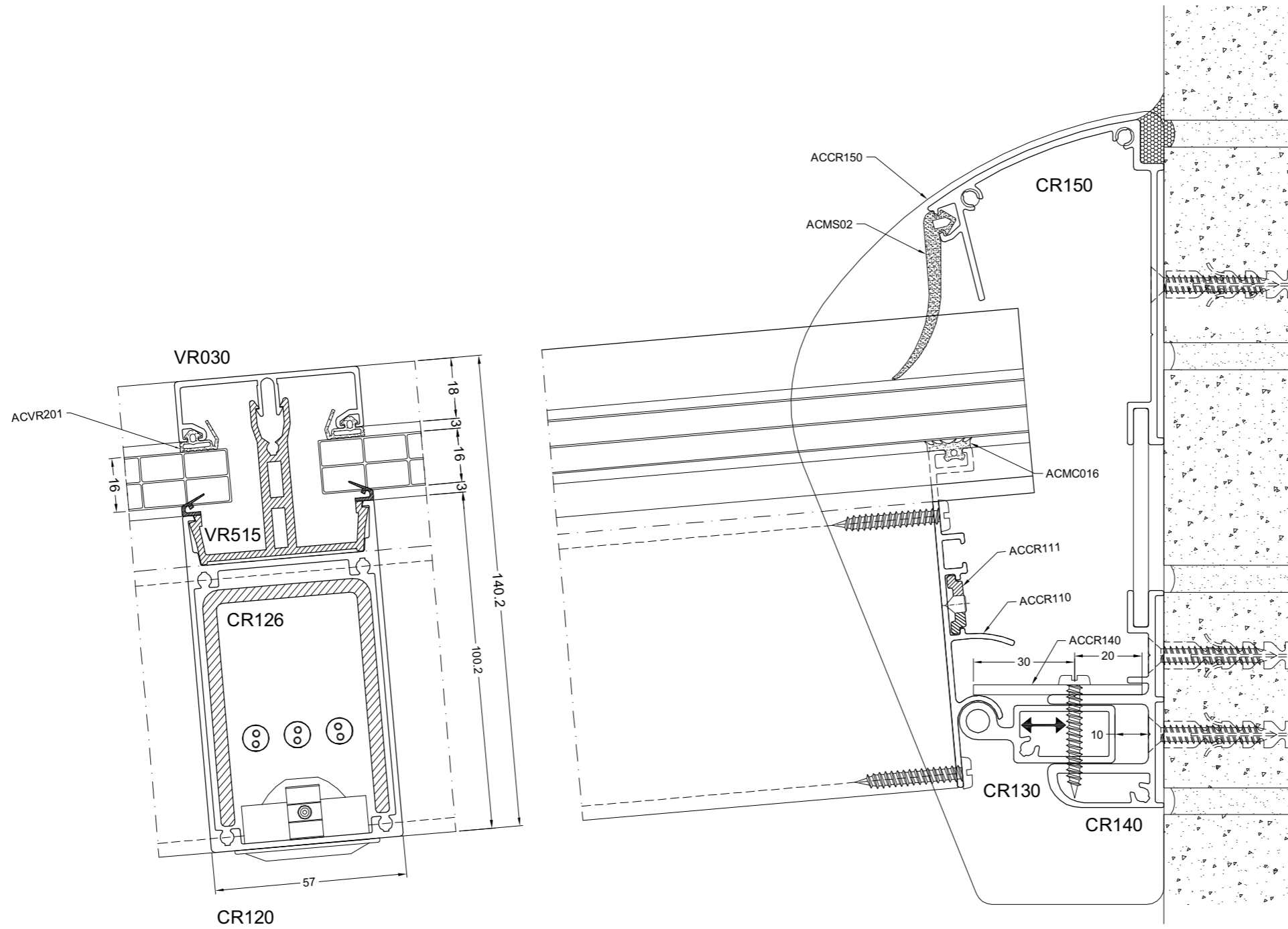

snede_2

2B

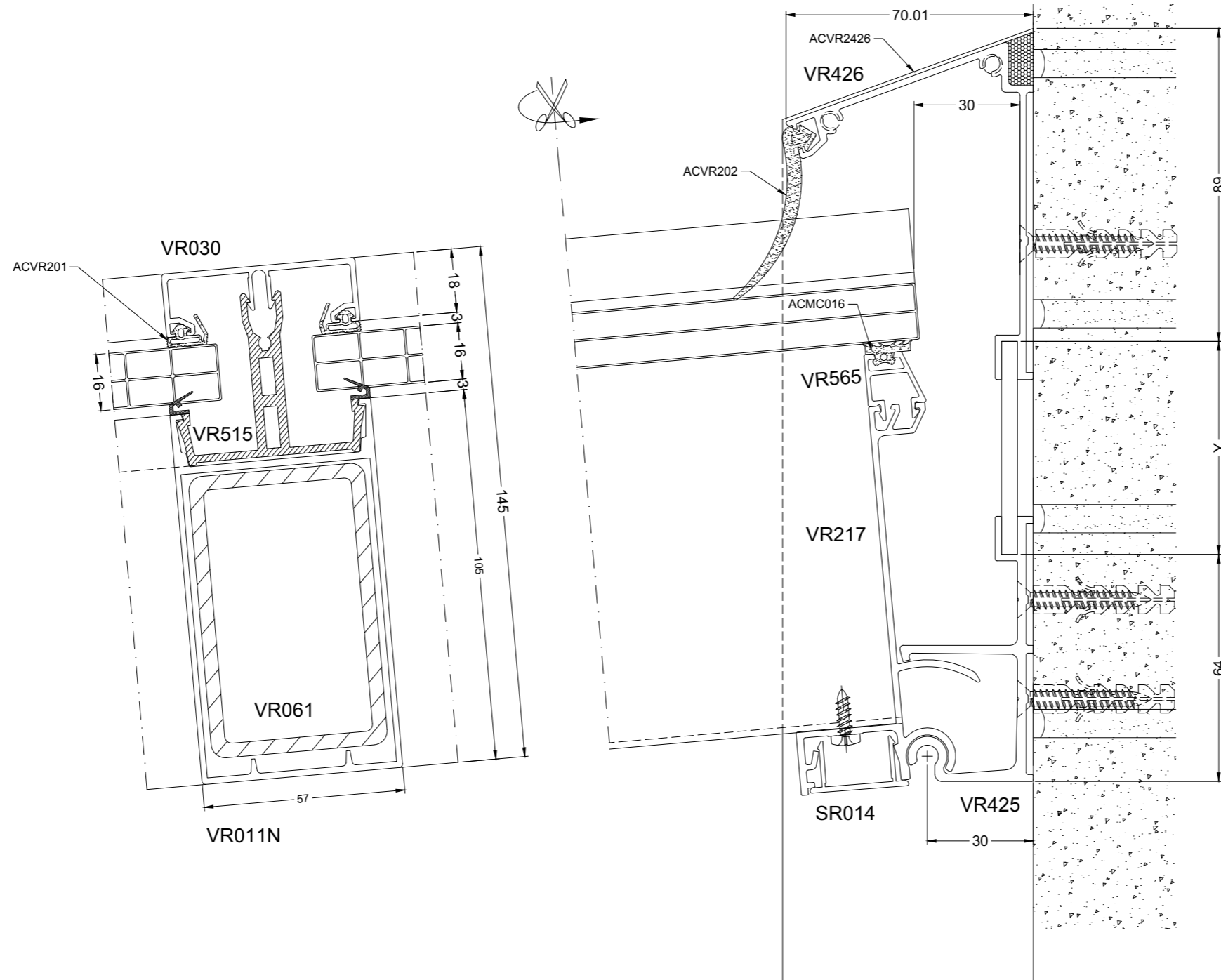

sneede_2B

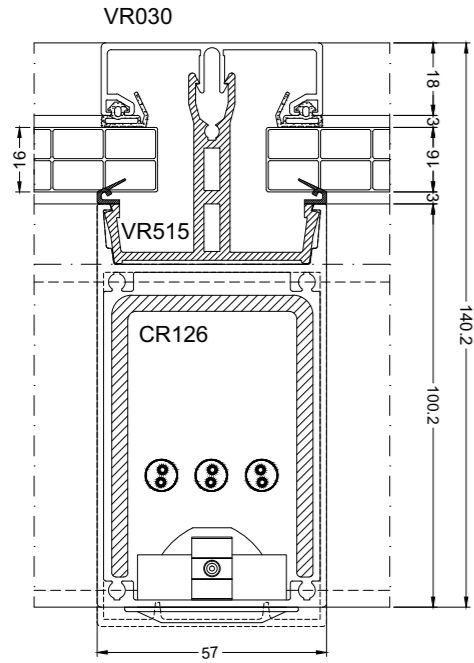

CR120/VR011N

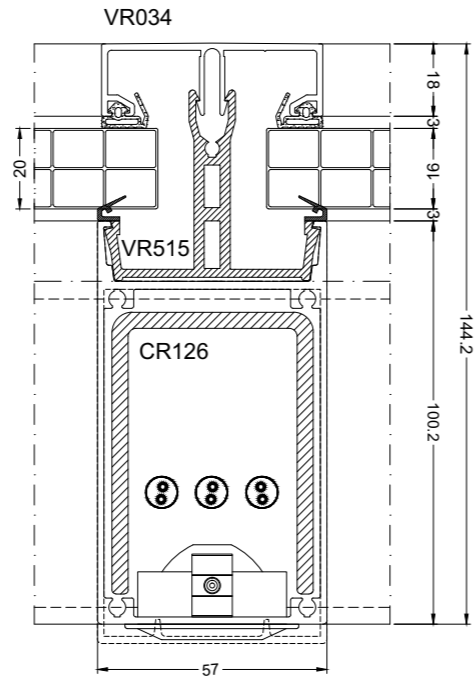

CR120/VR011N

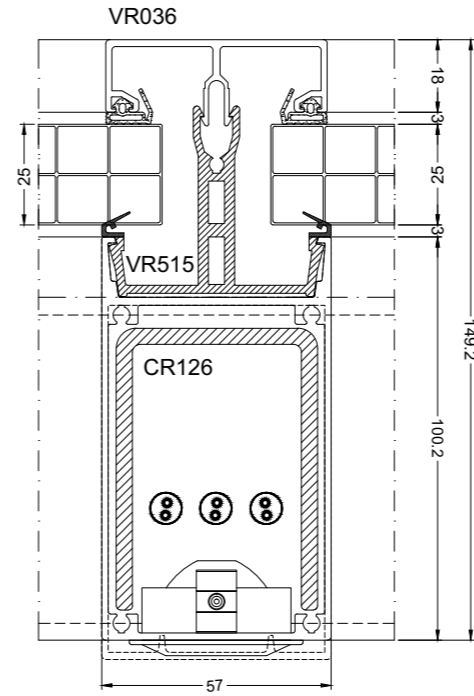

CR120/VR011N

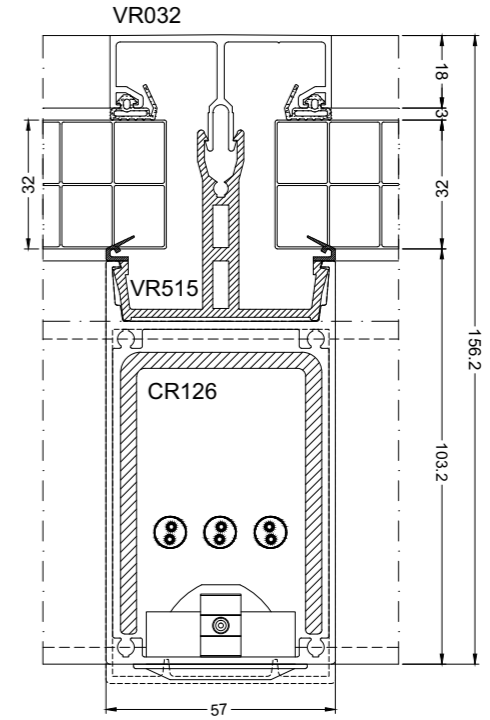

CR120/VR011N

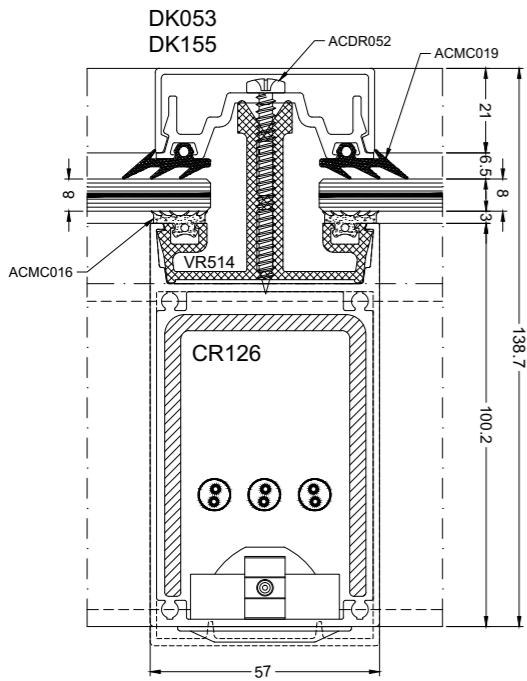

CR120/VR011N

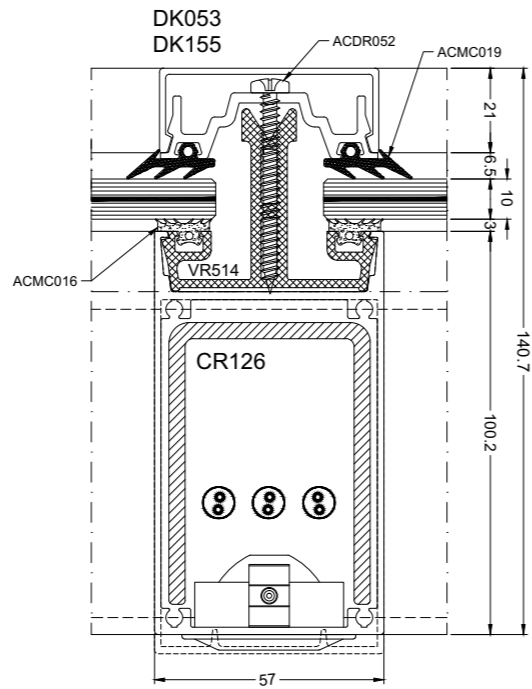

CR120/VR011N

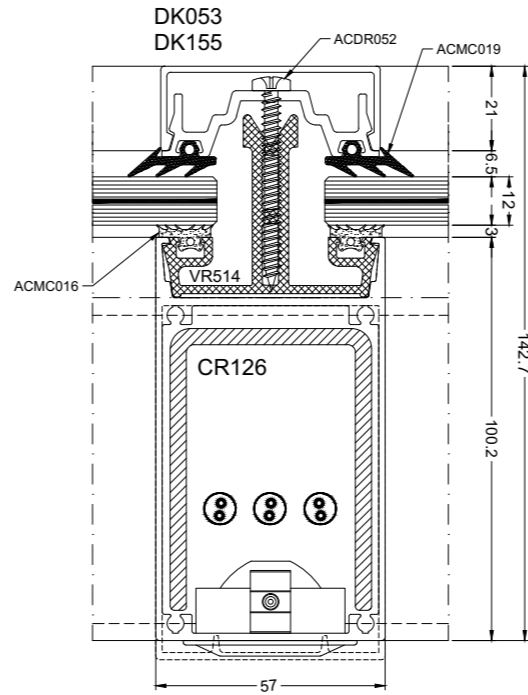

CR120/VR011N

snede_3

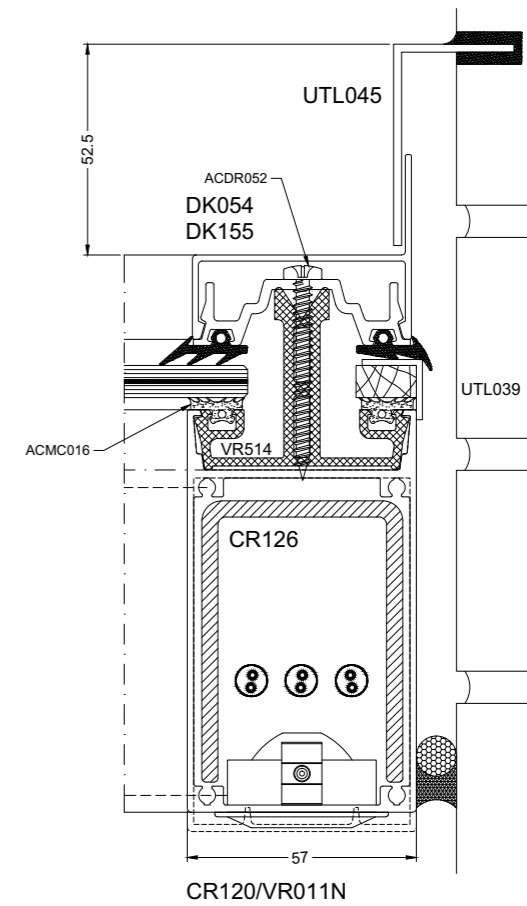
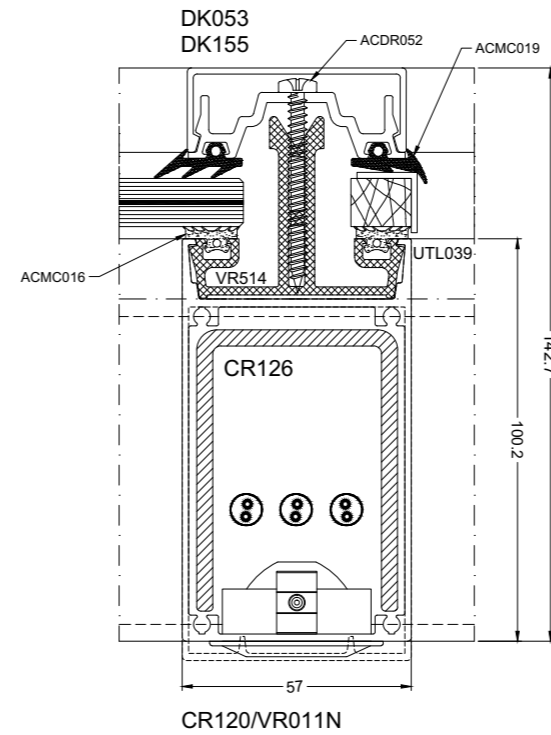
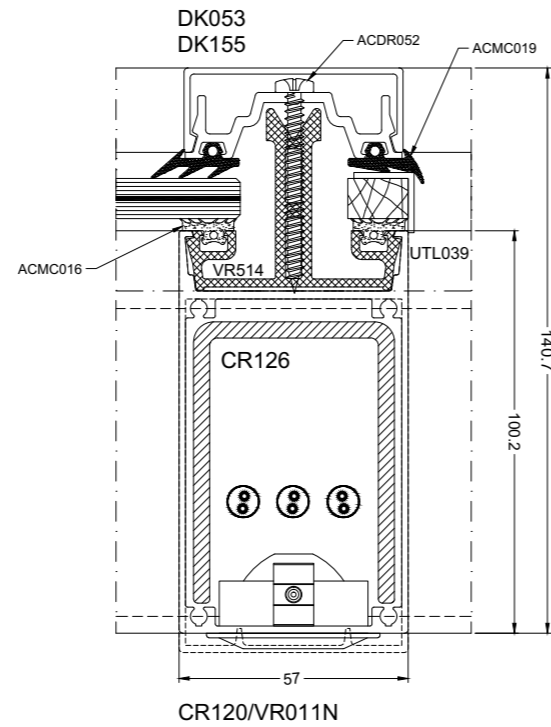
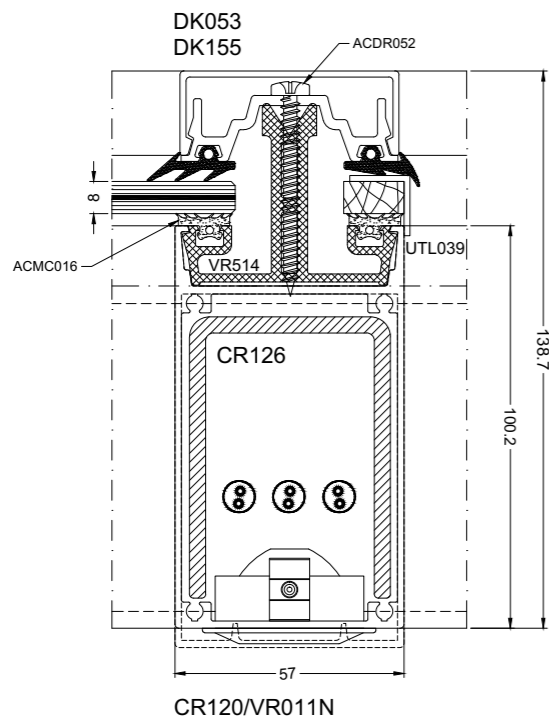
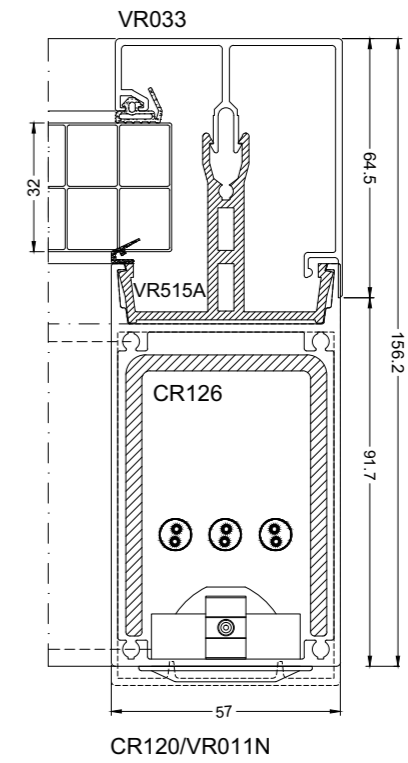
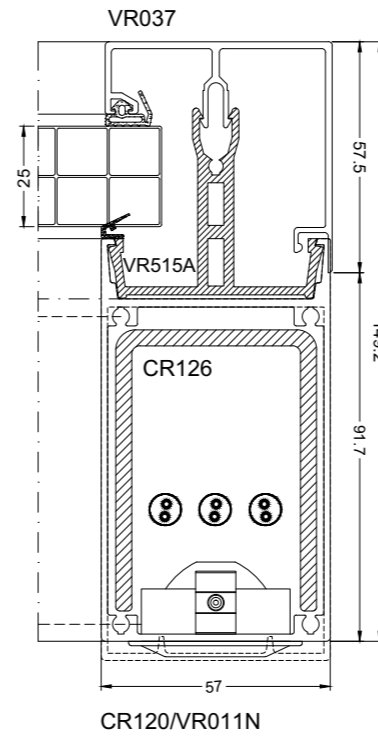
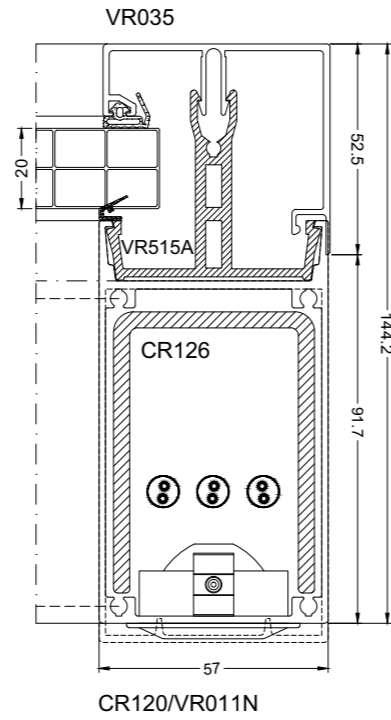
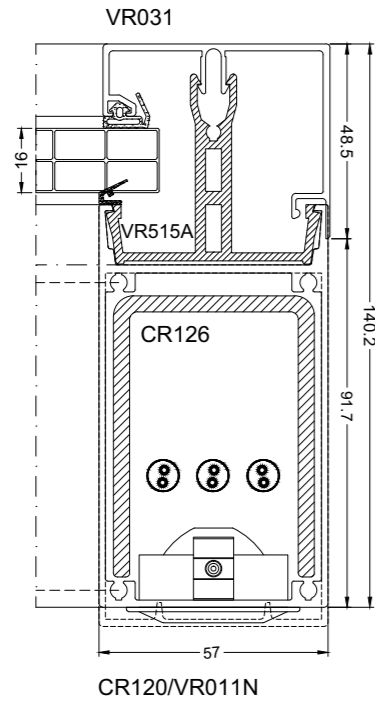

snede_4

1

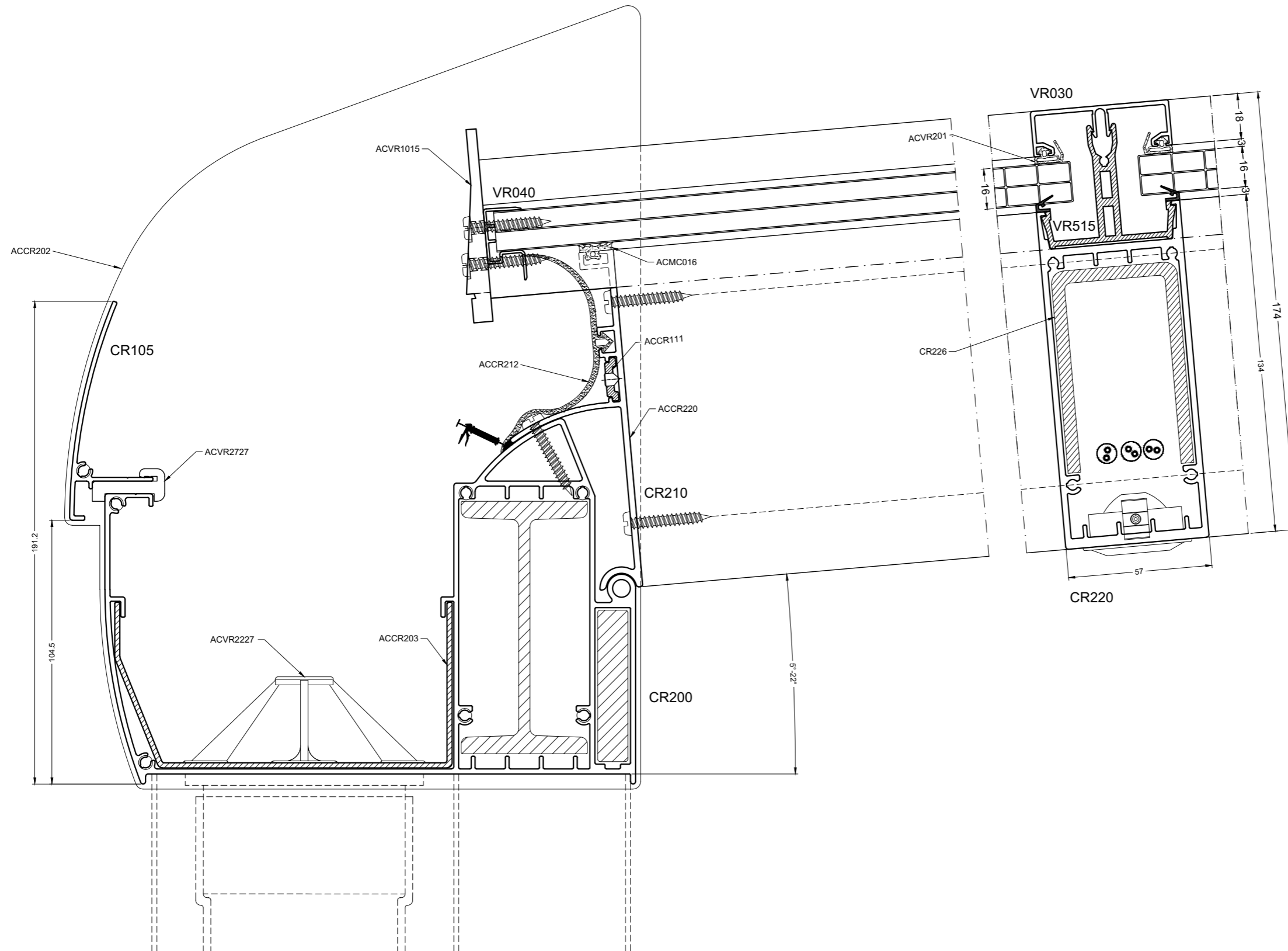

snede_1_Poly+

DOORSNEDES - COUPES - SCHNITT-SECTIONS

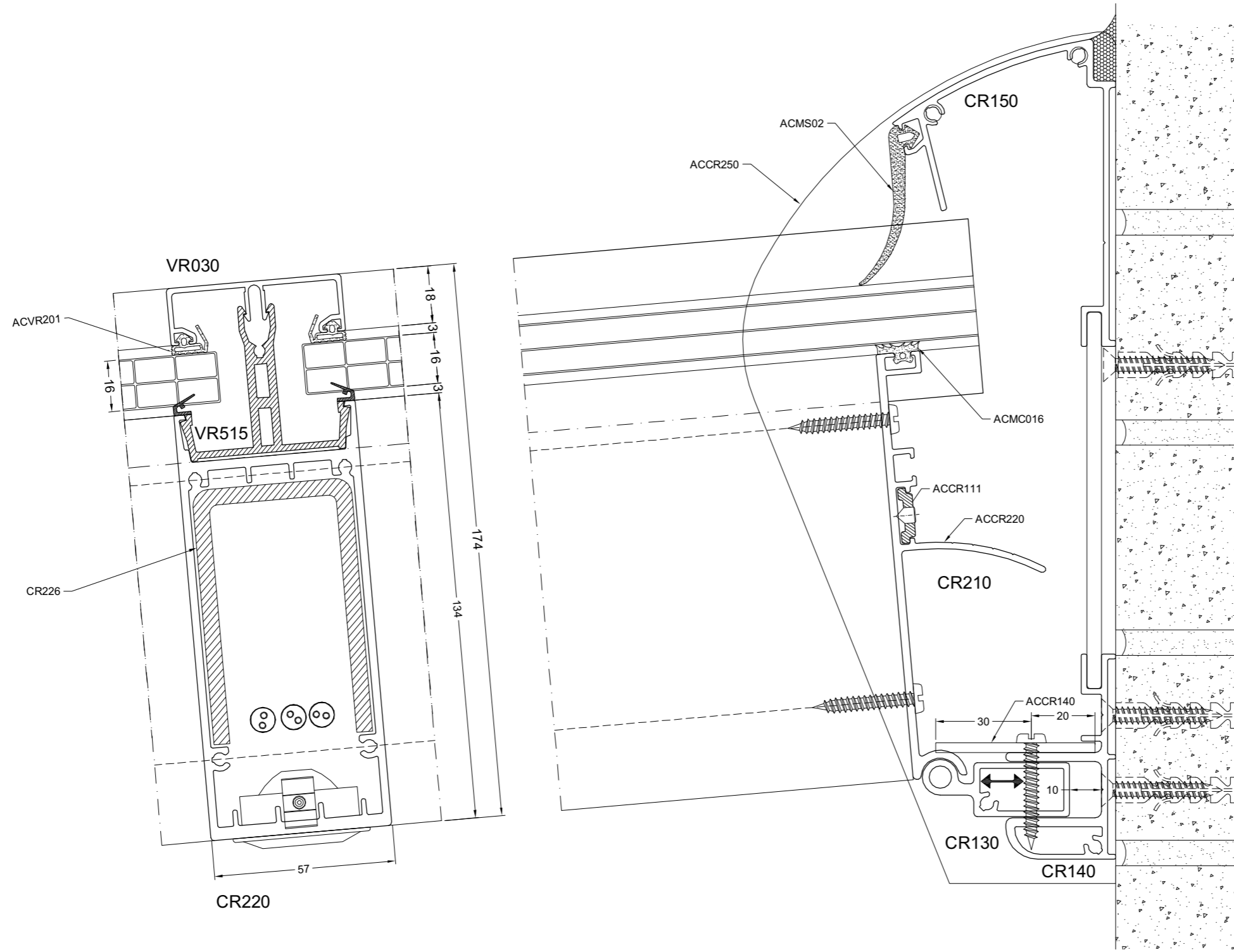

snele_2_Poly+

3

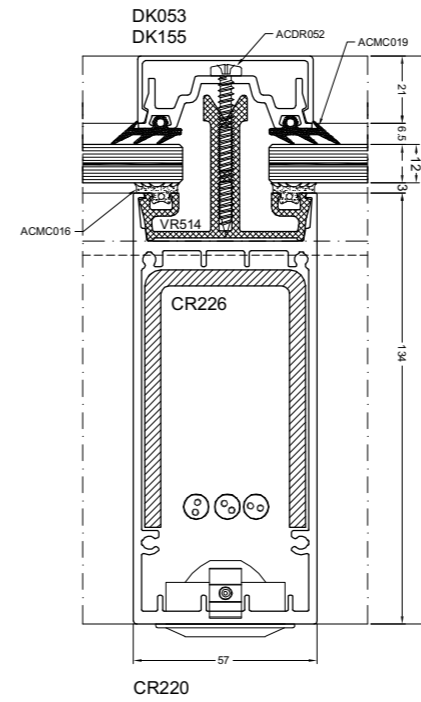
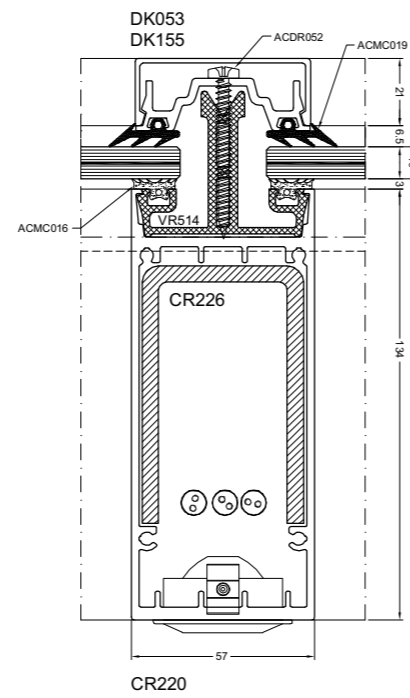
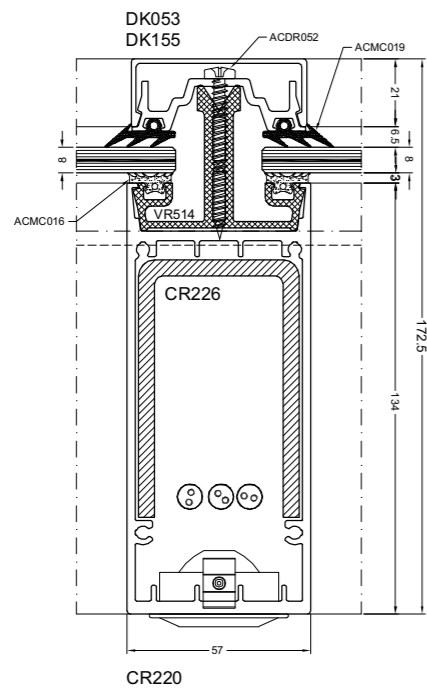
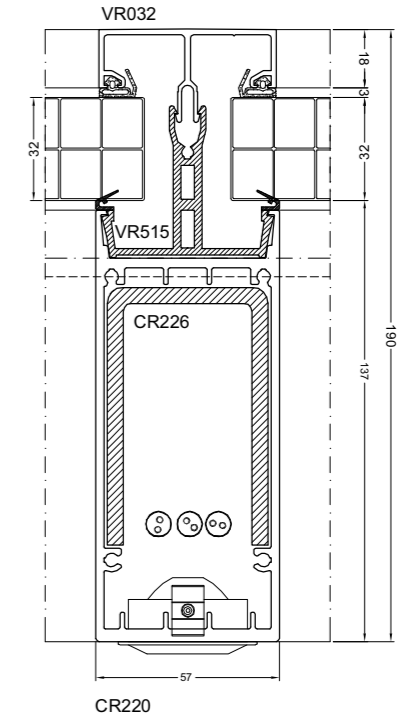
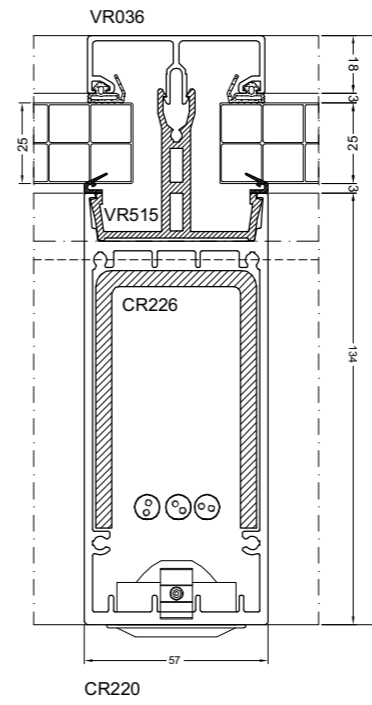
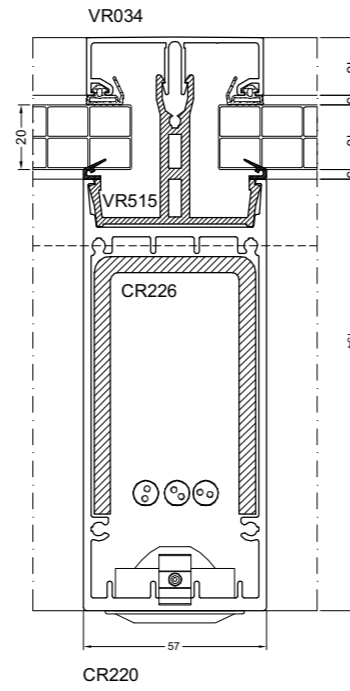
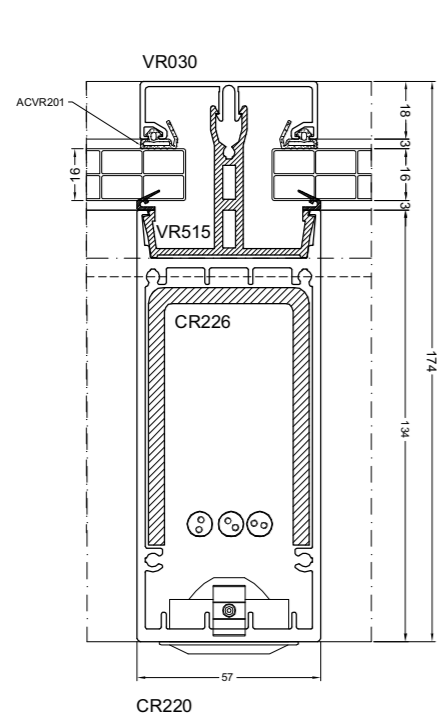

snede_3_Poly+

DOORSNEDES - COUPES - SCHNITT-SECTIONS

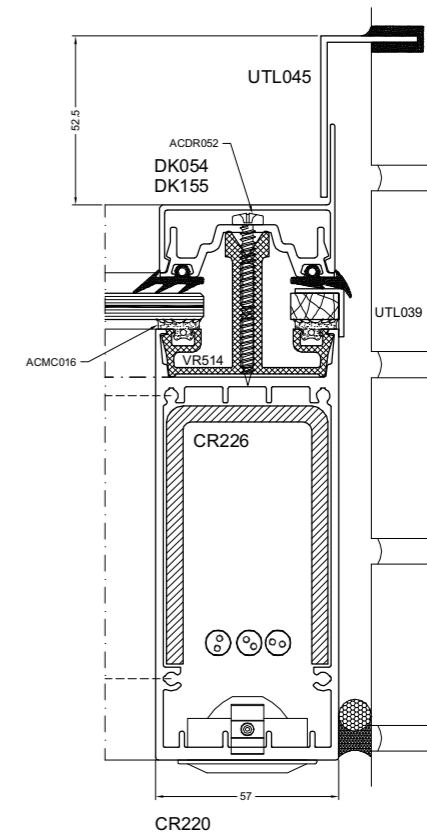
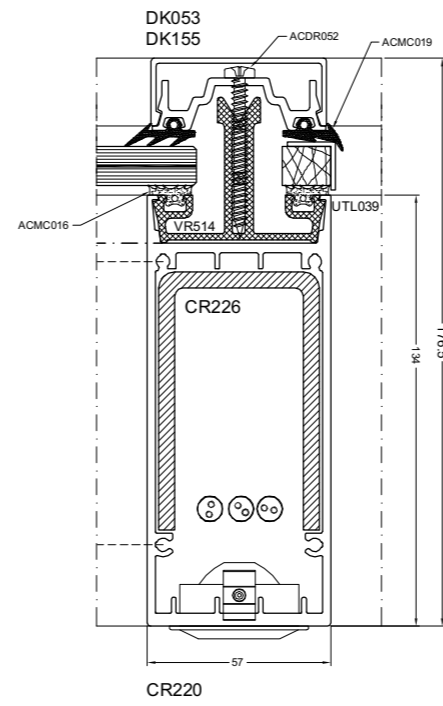
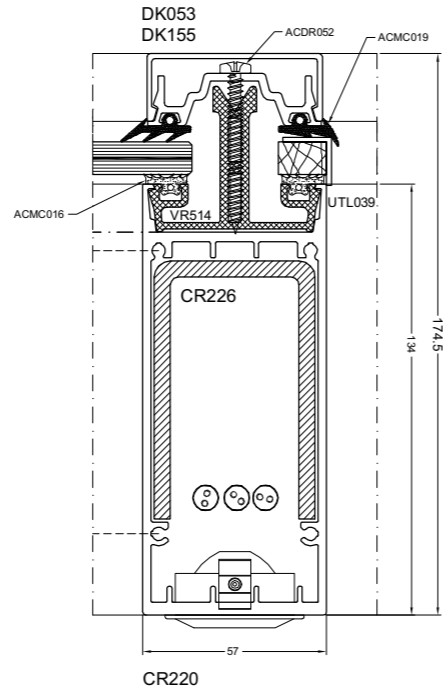
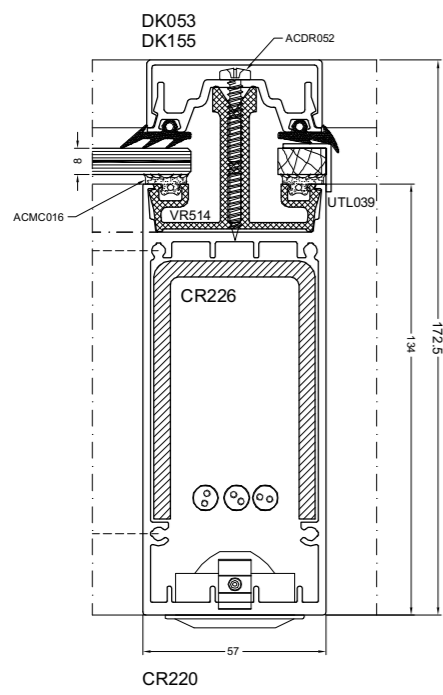
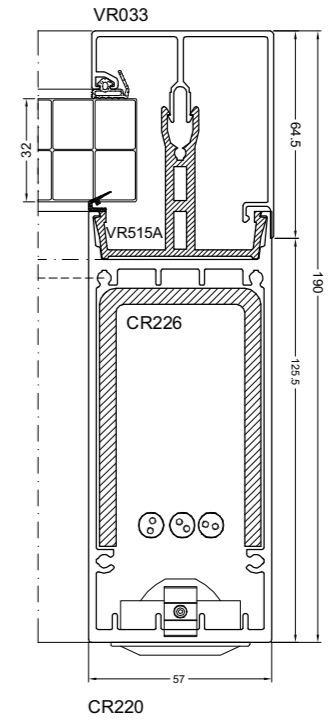
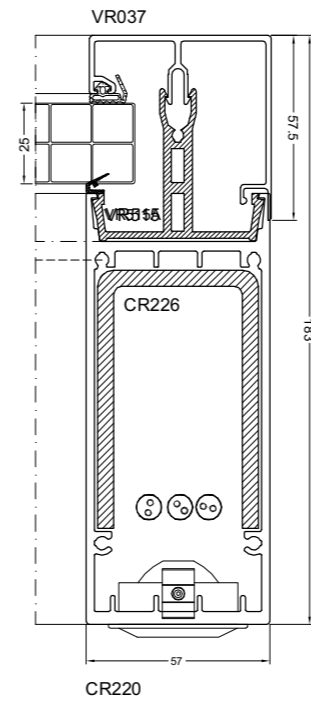
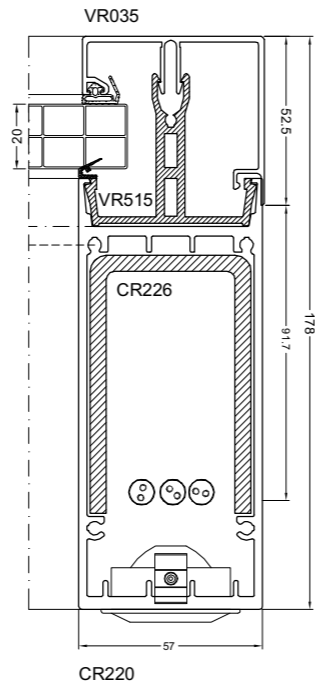
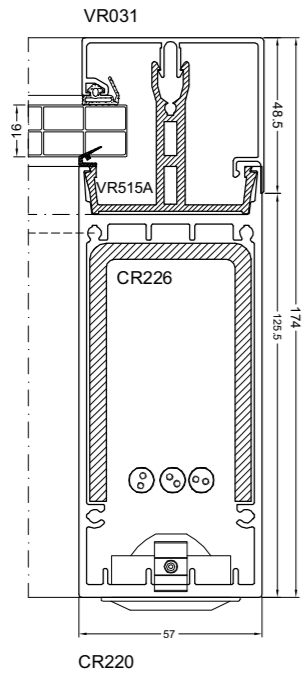

ZAAGTABEL MET POLYCARBONAAT
TABLE DE SCIAGE AVEC POLYCARBONAT
ZUSCHNITT TABEL MIT POLYCARBONAT
SAWING TABLE WITH POLYCARBONATE

Polycarbonaat
 Polycarbonate
 Polycarbonat
 Polycarbonate

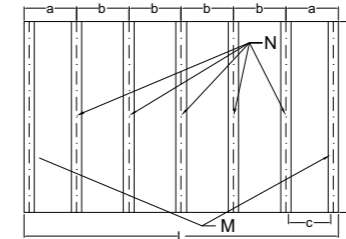
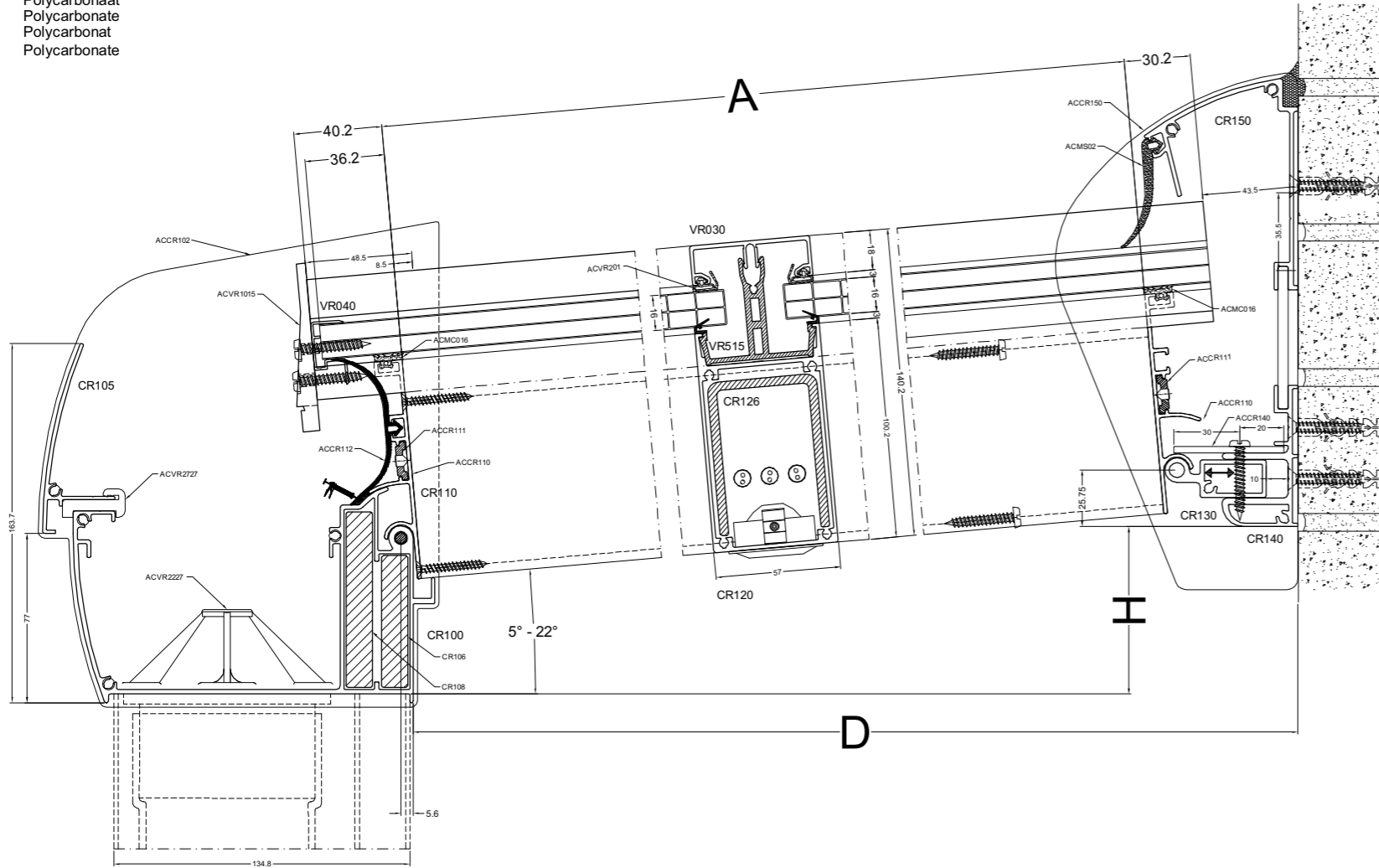

L
D
N
M
$A = \sqrt{(D-49.5)^2 + (H-45.25)^2} - 15$
$\alpha = \text{ARCTAN} \left[\frac{H-45.25}{D-49.5} \right]$

N = Aantal Dakliggers
 Nombre de montants
 Anzahl Balken
 Number of Beams
 M = Aantal Zijliggers
 Montants de coté
 Anzahl Seitenbalken
 Number of Sidebeams

PROFIEN PROFILS PROFILE PROFILES	AFBEELDING IMAGE BILD PICTURE	SNEDE COUPE SCHNITT PROFILES	AANTAL QUANTITE ANZAHL NUMBER	FORMULE FORMULE FORMEL FORMULA
CR100 (+CR105)			1	L
CR106			1	L
CR108			1	L
CR110			(N+1) x 2	b-57
CR130			1	L
CR140			1	L
CR150			1	L
CR120			N+M	A
CR126			N+M	A
VR515			N	A+70.4
VR515A			M	A+70.4

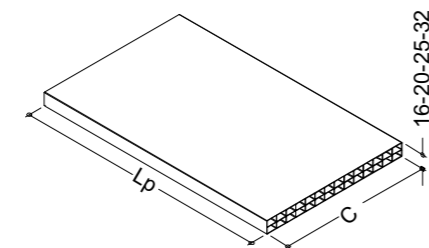

	AANTAL QUANTITE ANZAHL NUMBER	FORMULE FORMULE FORMEL FORMULA
Lp	N+1	A+66.4
c	N+1	b-27

TOEBEHOREN ACCESSOIRES ZUBEHÖRTEILE ACCESSORIES	AANTAL QUANTITE ANZAHL NUMBER	FORMULE FORMULE FORMEL FORMULA
ACCR102	2	
ACCR111	(Nx4) + (Mx2)	
ACCR112	1	L
ACCR140	M+N	
ACCR150	2	
ACMC016	(Nx2) + 2	b-57
ACMS02	1	L
ACVR201	2x(N+M)	A+70.4
ACVR2227	1	
ACVR2727	L/500	

Polycarbonaat Polycarbonat Polycarbonate	16mm	20mm	25mm	32mm				
	VR030	VR034	VR036	VR032		N	A+70.4	
	VR031	VR035	VR037	VR033		M	A+70.4	
	VR040	VR043	VR044	VR041		N-1	b-57	
	VR040	VR043	VR044	VR041		M	a-57	

Polycarbonaat Polycarbonat Polycarbonate	16mm 20mm 25mm	32mm		
	ACVR1015	ACVR2015	N+M	

ZAAGTABEL MET ENKEL GLAS
TABLE DE SCIAGE AVEC VITRAGE SIMPLE
ZUSCHNITT TABEL MIT EINZIGES GLAS
SAWING TABLE SINGLE GLAZING

Enkel glas 8-10-12mm
 Vitrage simple 8-10-12mm
 Einzige verglasung 8-10-12mm
 single glazing 8-10-12mm

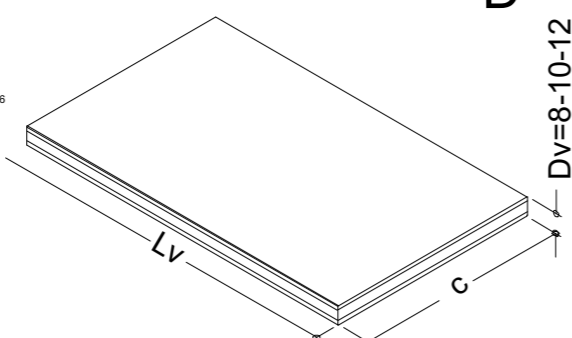
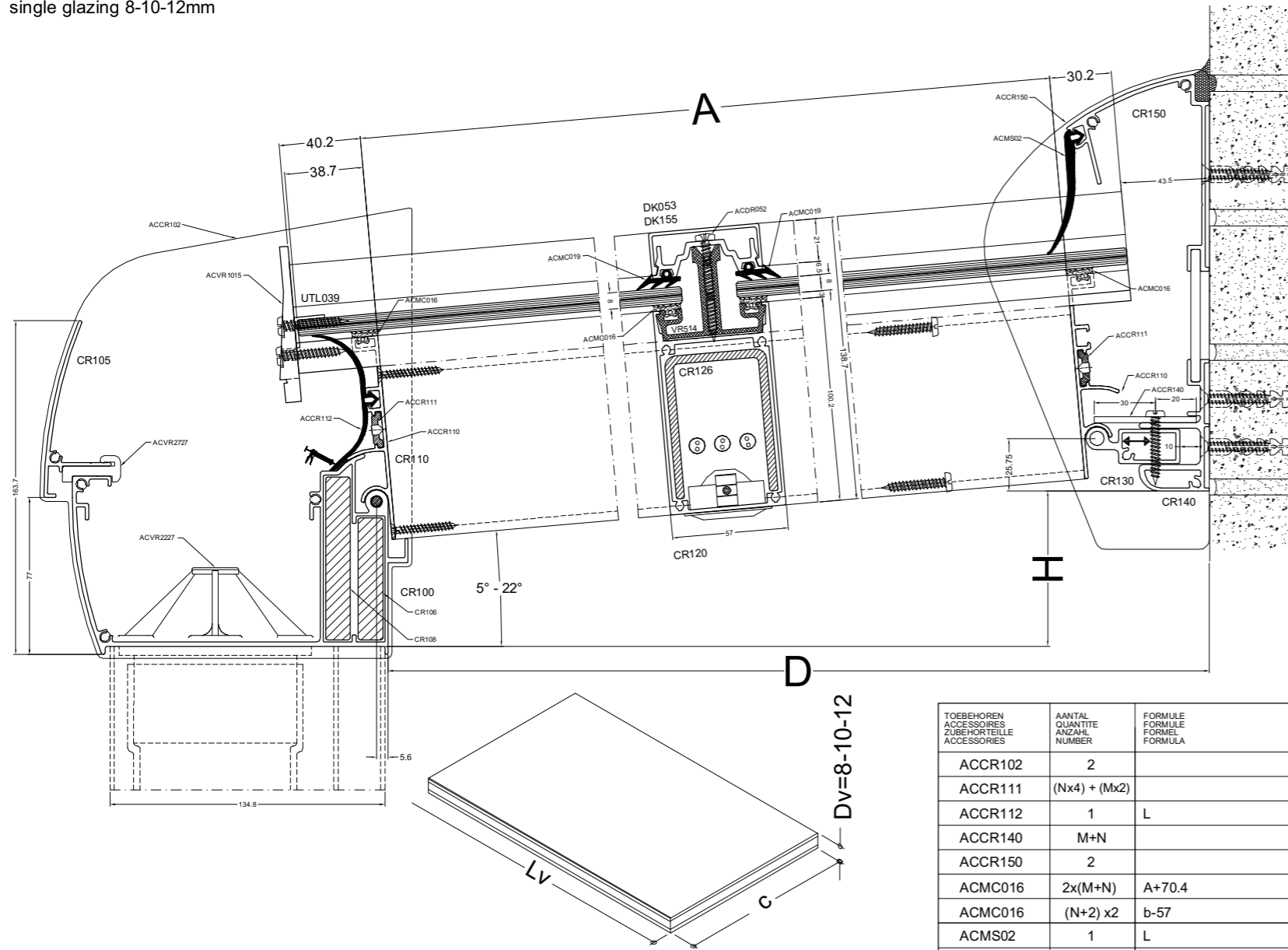

	AANTAL QUANTITE ANZAHL NUMBER	FORMULE FORMULE FORMEL FORMULA
Lp	N+1	A+66.4
c	N+1	b-27

TOEBEHOREN ACCESSOIRES ZUBEHÖRTEILE ACCESSORIES	AANTAL QUANTITE ANZAHL NUMBER	FORMULE FORMULE FORMEL FORMULA
ACCR102	2	
ACCR111	(Nx4) + (Mx2)	
ACCR112	1	L
ACCR140	M+N	
ACCR150	2	
ACMC016	2x(M+N)	A+70.4
ACMC016	(N+2) x2	b-57
ACMS02	1	L
ACMC019	2x(N+M)	A+70.4
ACVR2227	1	
ACVR2727	L/500	

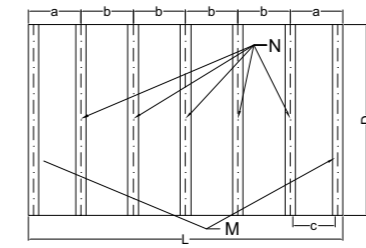

N = Aantal Dakliggers
 Nombre de montants
 Anzahl Balken
 Number of Beams
 M = Aantal Zijliggers
 Montants de côté
 Anzahl Seitenbalken
 Number of Sidebeams

L
D
N
M
$A = \sqrt{(D-49.5)^2 + (H-45.25)^2} - 15$
$\alpha = \text{ARCTAN} \left[\frac{H-45.25}{D-49.5} \right]$

PROFIELEN PROFILS PROFILE PROFILES	AFBEELDING IMAGE BILD PICTURE	SNEDE COUPE SCHNITT PROFILES	AANTAL QUANTITE ANZAHL NUMBER	FORMULE FORMULE FORMEL FORMULA
CR100 (+CR105)			1	L
CR106			1	L
CR108			1	L
CR110			2x(N+1)	b-27
CR130			1	L
CR140			1	L
CR150			1	L
CR120			N+M	A
CR126			N+M	A
DK053			N+M	A+70.4
DK153			N+M	A+70.4
UTL039			N+1	b-27

BEREKENING C1/C2/Y
 CALCULATION C1/C2/Y
 BEREICHNUNG C1/C2/Y
 CALCULATION C1/C2/Y

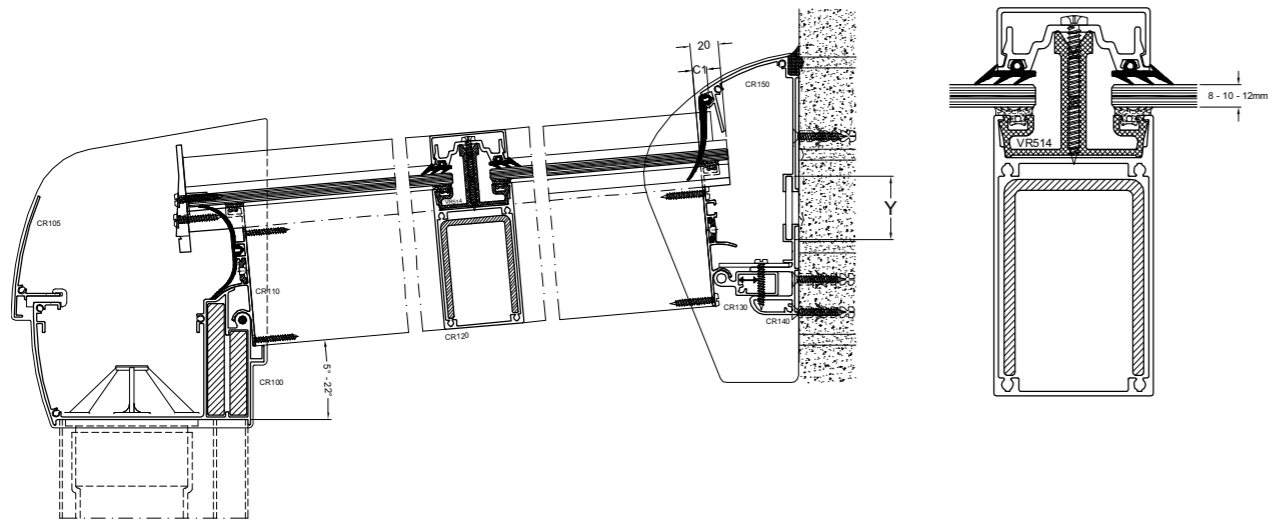
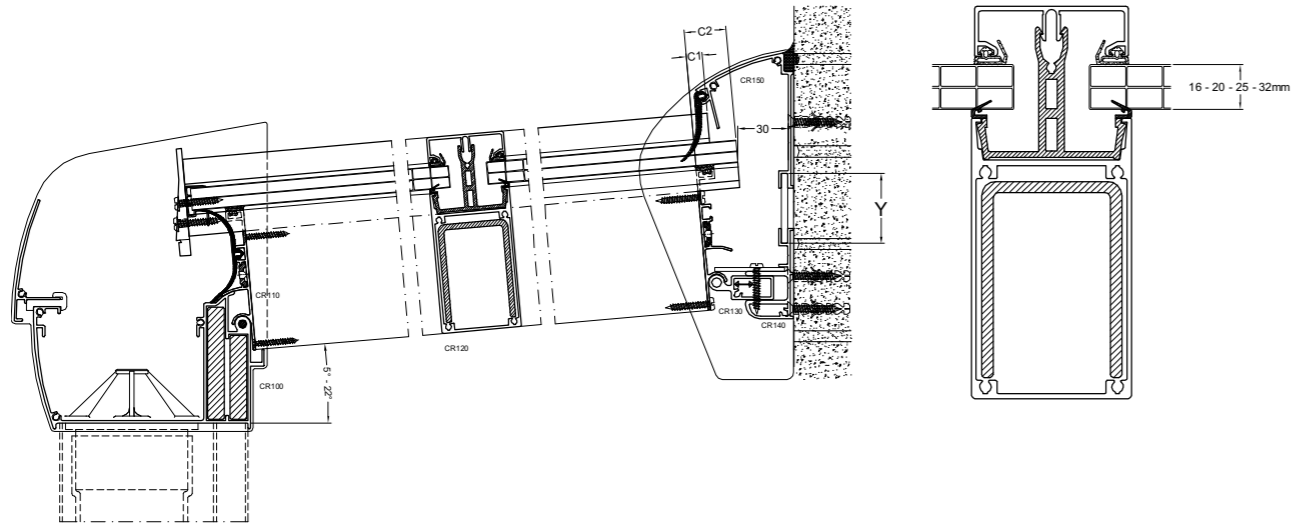

C1	5	6	7	8	9	10	11	12	13	14	15	16	17	18	19	20	21	22
16	12	14	16	18	20	22	25	26	28	30	30	34	36	38	40	42	44	46
20	12	14	16	18	20	22	25	26	28	30	32	35	37	38	40	43	46	48
25	12	14	16	18	20	22	25	26	30	32	34	36	39	41	43	45	47	50
32	12	14	16	18	20	22	25	26	30	33	34	36	39	42	45	48	50	51
C2	36.4	37.9	39.5	41	42.6	44.1	45.7	47.3	49	50.6	52.3	53.9	55.6	57.4	58.8	60.5	62.5	64.5

Y	5	6	7	8	9	10	11	12	13	14	15	16	17	18	19	20	21	22
16	50	50	50	50	50	50	50	50	50	50	50	50	50	50	55	55	55	55
20	55	55	55	55	55	55	55	55	55	55	55	55	55	55	60	60	60	60
25	60	60	60	60	60	60	60	60	60	60	60	60	60	60	65	65	65	65
32	65	65	65	65	65	65	65	65	65	65	65	65	65	65	70	70	70	70

C1	5	6	7	8	9	10	11	12	13	14	15	16	17	18	19	20	21	22
8	10	13	15	17	19	21	23	24	26	29	31	33	-23	-21	-19	-17	-15	-13
10	10	13	15	17	19	21	23	24	26	29	31	33	-23	-21	-19	-17	-15	-13
12	10	13	15	17	19	21	23	24	26	29	31	33	-23	-21	-19	-17	-15	-13
CR150													CR250					
Y	5	6	7	8	9	10	11	12	13	14	15	16	17	18	19	20	21	22
8	45	45	45	45	45	45	45	45	45	50	50	50	40	40	40	40	40	40
10	50	50	50	50	50	50	50	50	50	55	55	55	40	40	40	40	40	40
12	55	55	55	55	55	55	55	55	55	60	60	60	40	40	40	40	40	40

Zaag_3

INBOUWVOORBEELD
EXEMPLE D'INSTALLATION
EINBAUBEISPIEL
INSTALLATION EXAMPLE

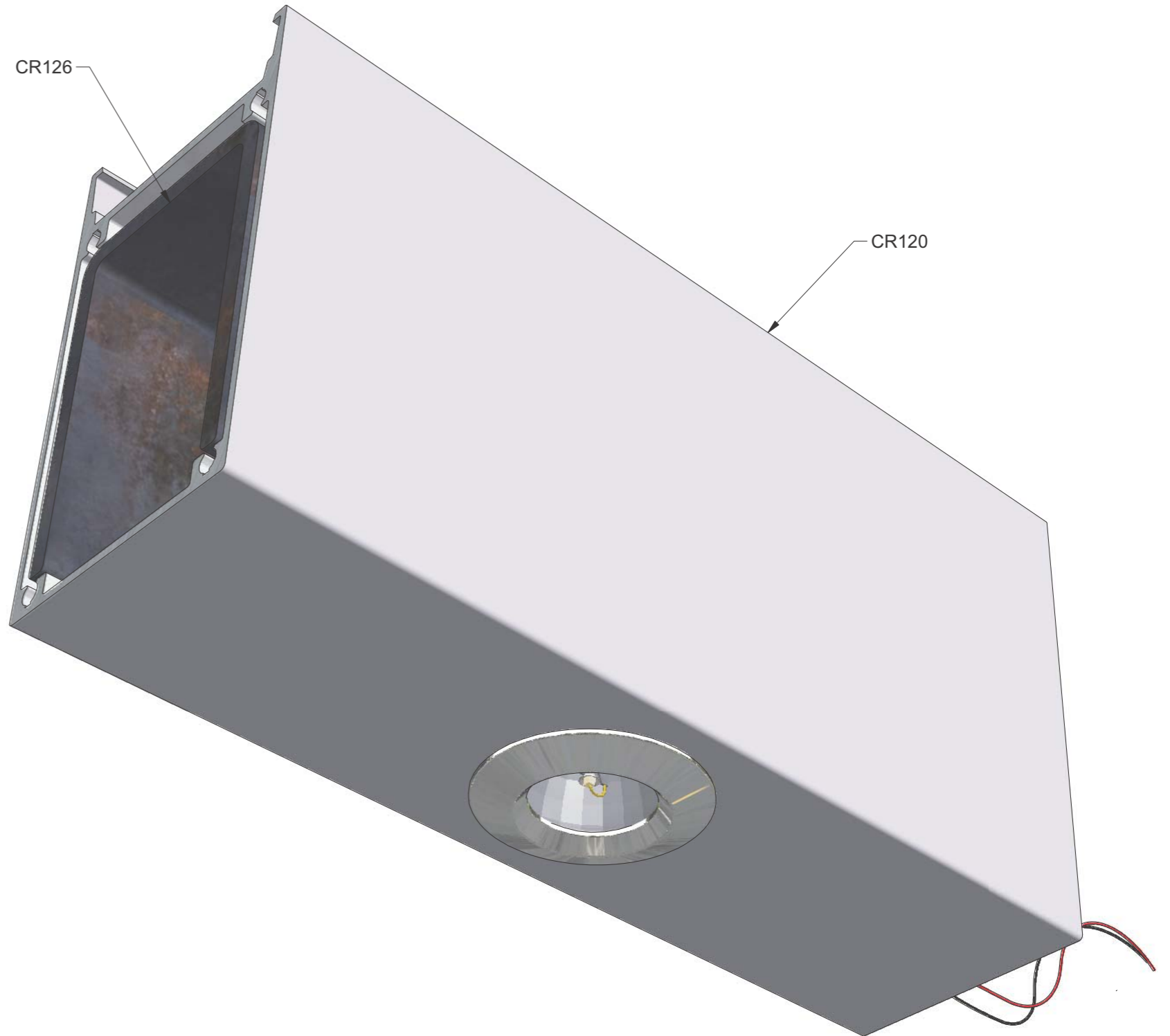
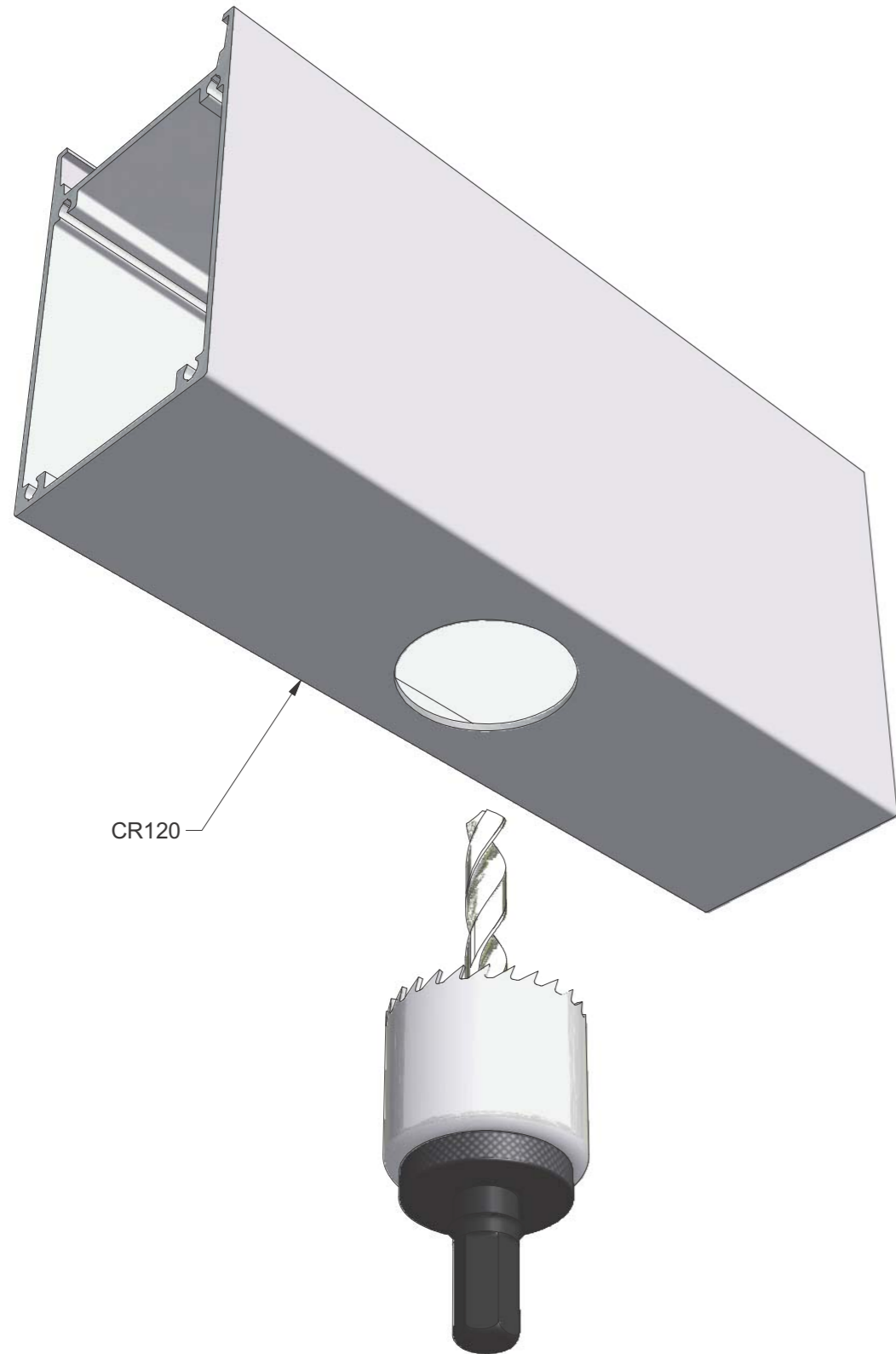

inbouw spotje.idw

MONTAGE ACCR110
MONTAGE ACCR110
MONTAGE ACCR110
MONTAGE ACCR110

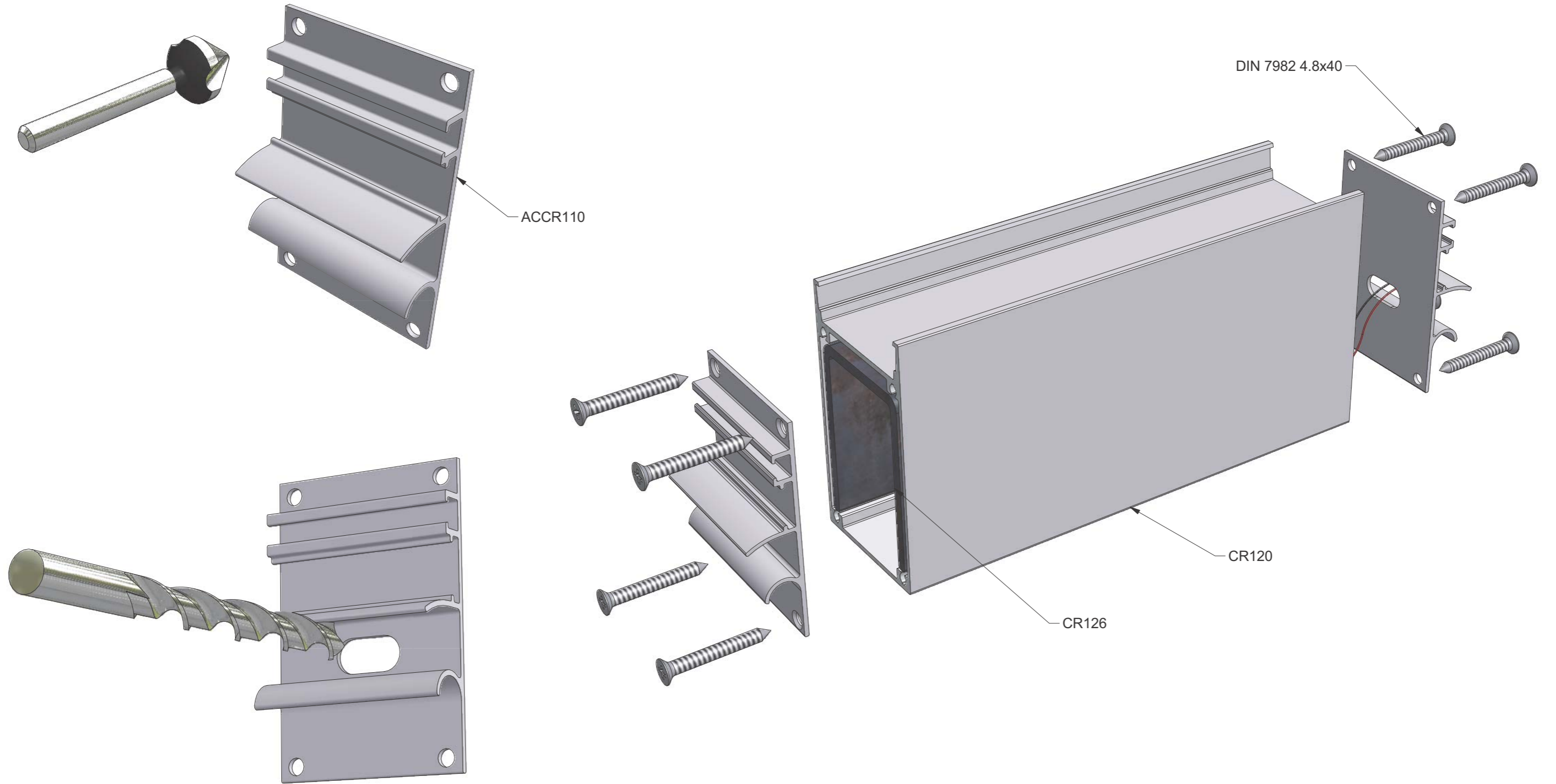

Montage ACCR110.idw

MONTAGE CR100 OP VR171 MET ACVR171
 MONTAGE CR100 SUR VR171 AVEC ACVR171
 MONTAGE CR100 AUF VR171 MIT ACVR171
 MONTAGE CR100 AT VR171 WITH ACVR171

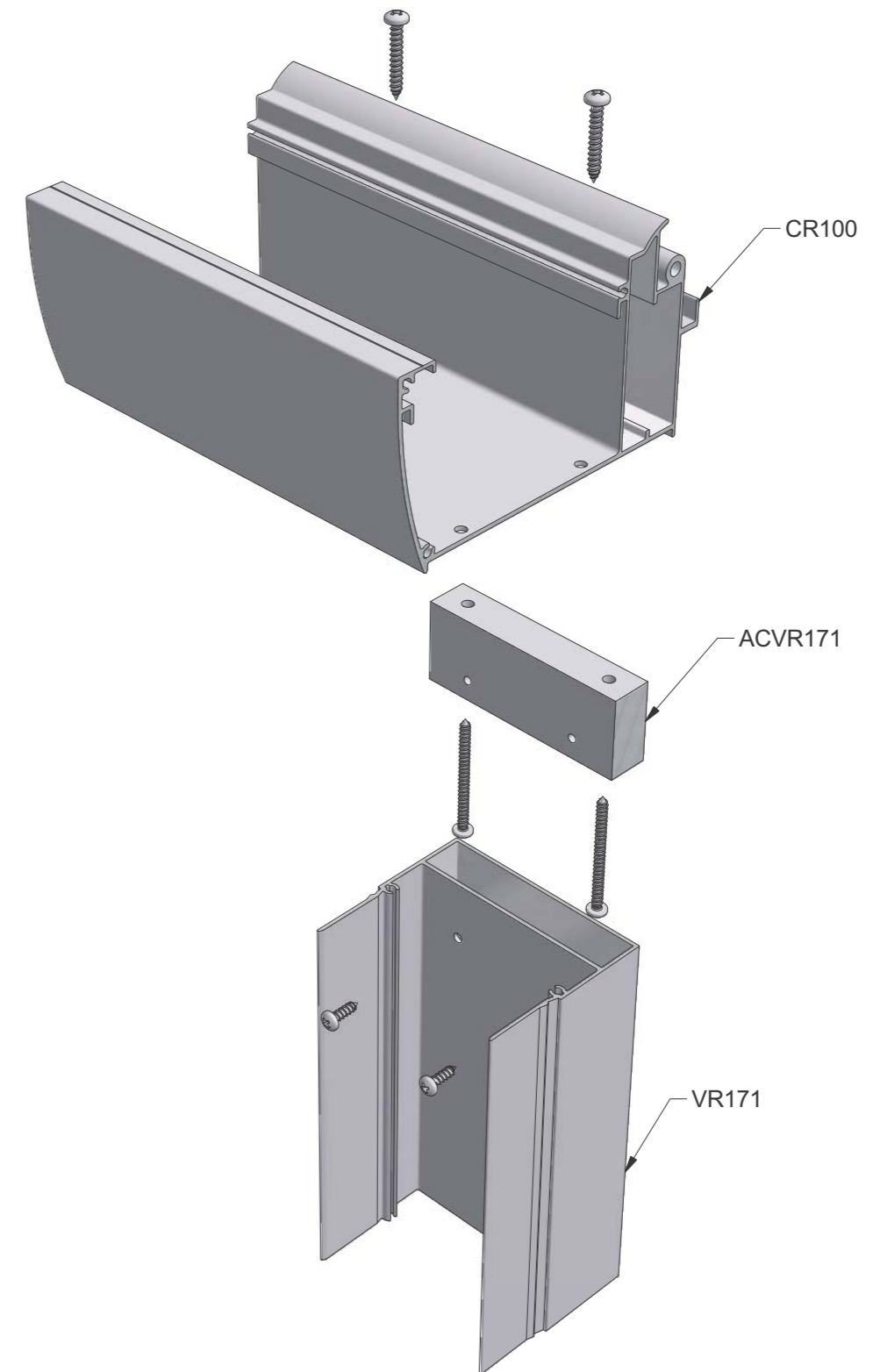
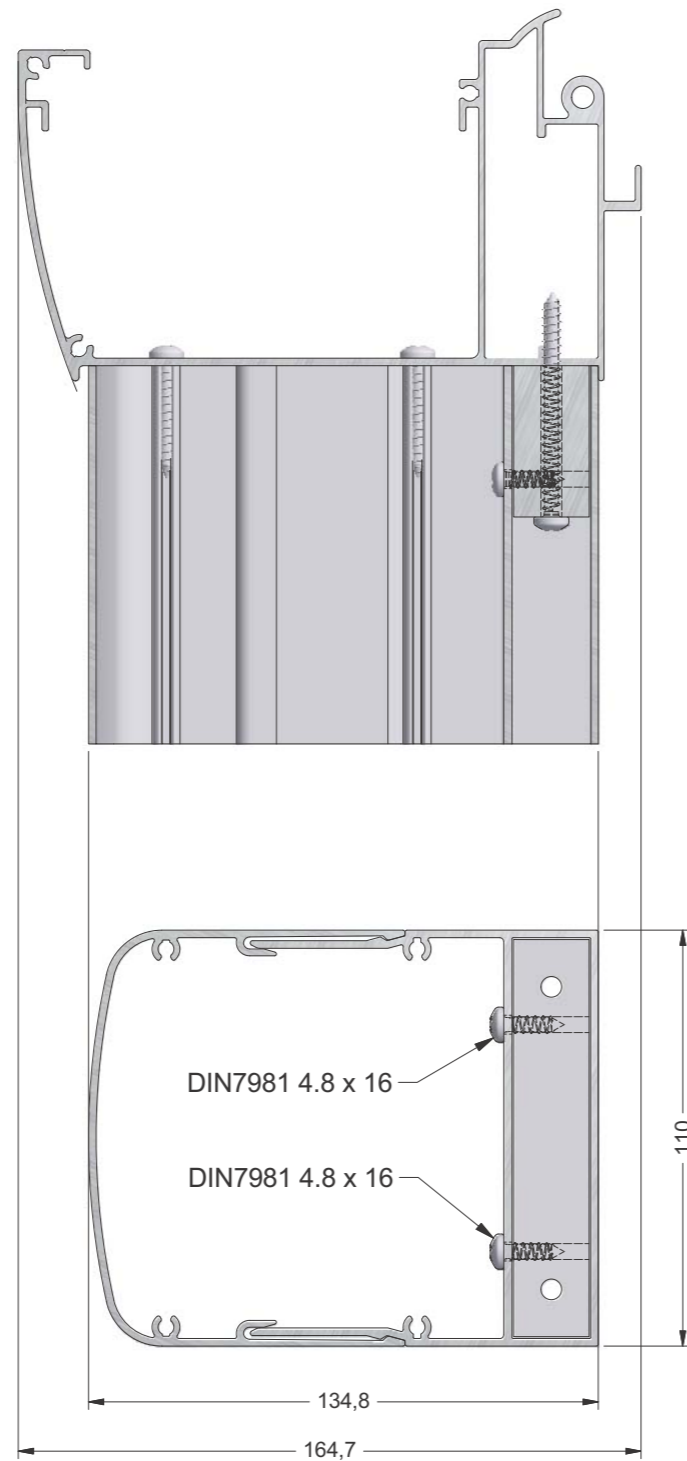

Montage goot op paal.idw

MONTAGE CR100 OP VR171 MET ACCR322
 MONTAGE CR100 SUR VR171 AVEC ACCR322
 MONTAGE CR100 AUF VR171 MIT ACCR322
 MONTAGE CR100 AT VR171 WITH ACCR322

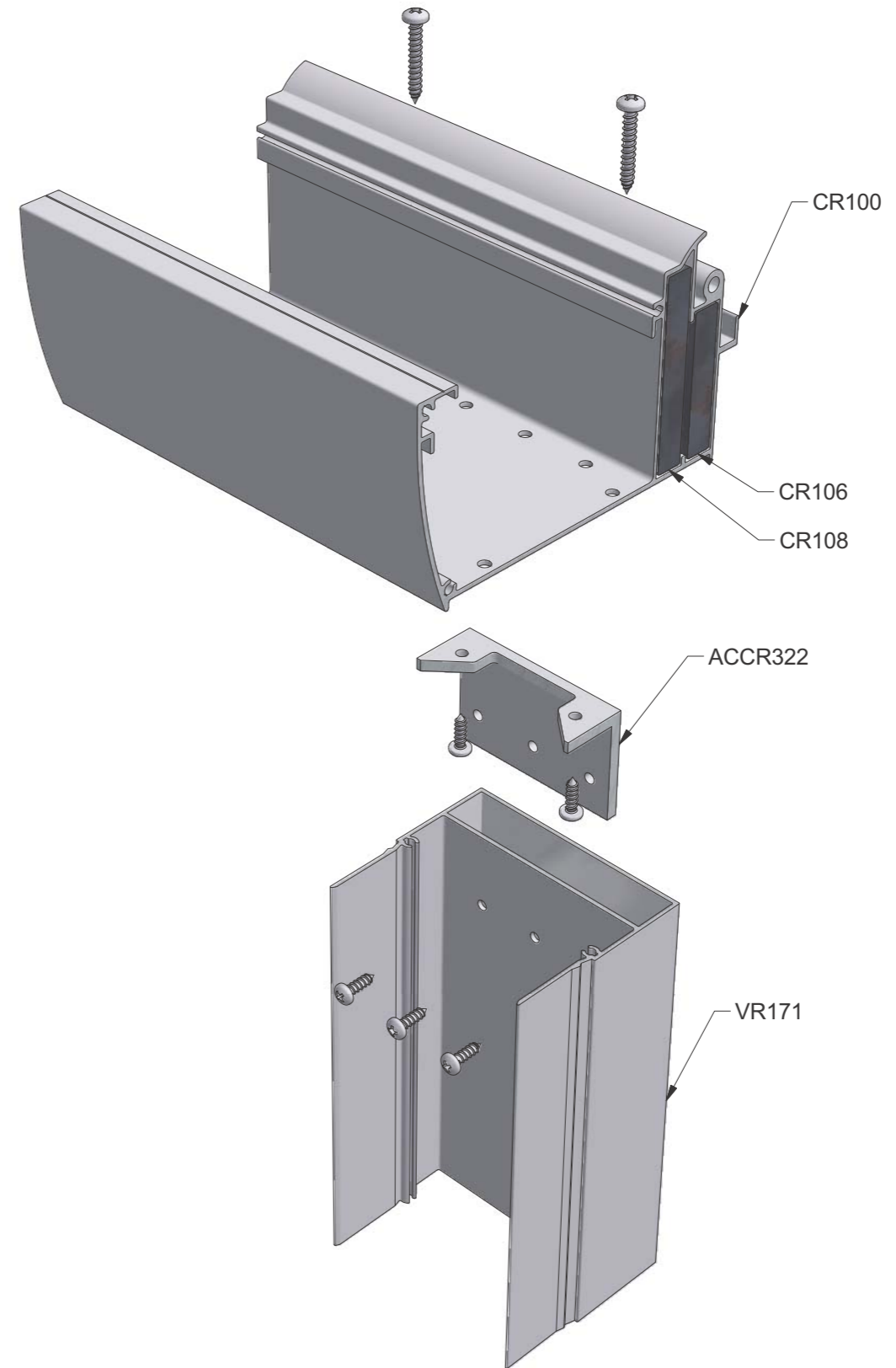
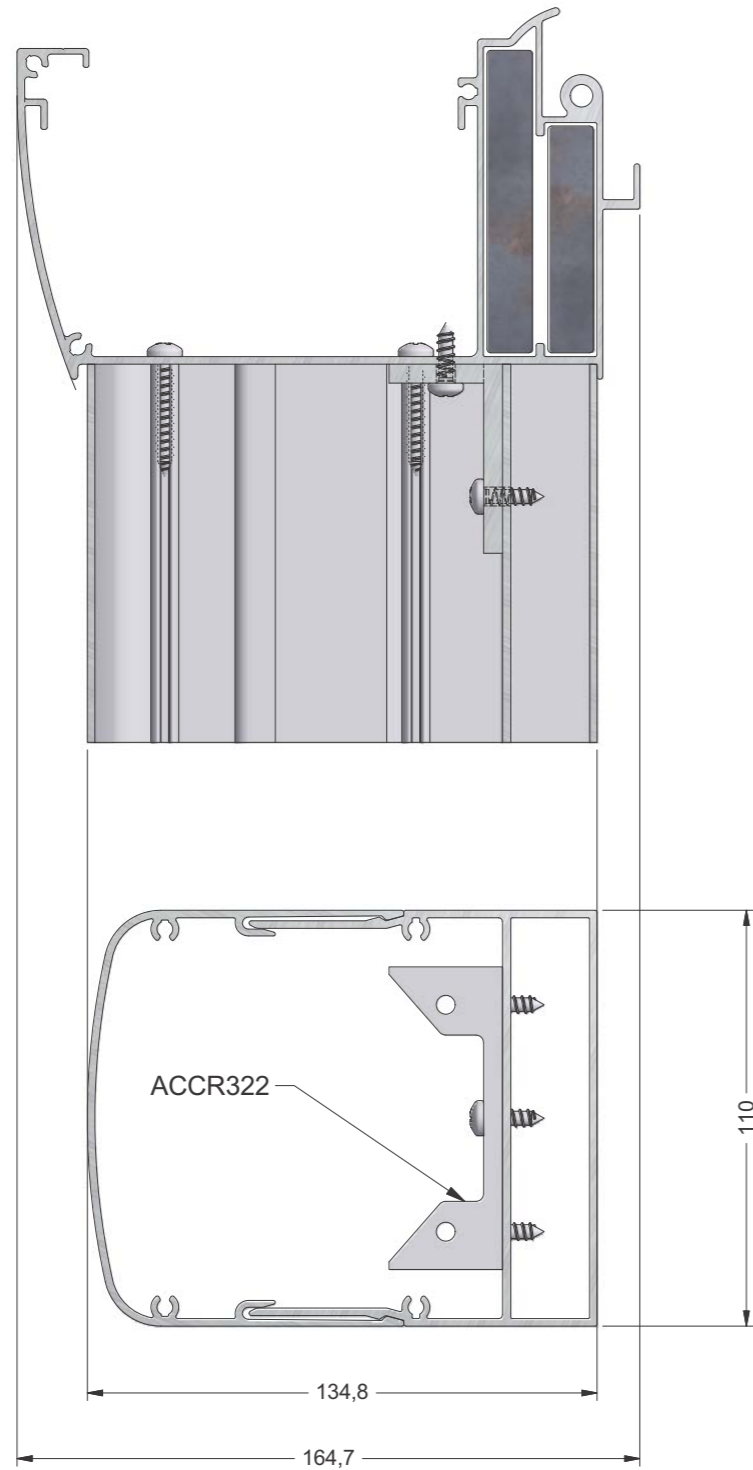

Montage goot op paal ACCR322.idw

MONTAGE ACVR2227
 MONTAGE ACVR2227
 MONTAGE ACVR2227
 MONTAGE ACVR2227

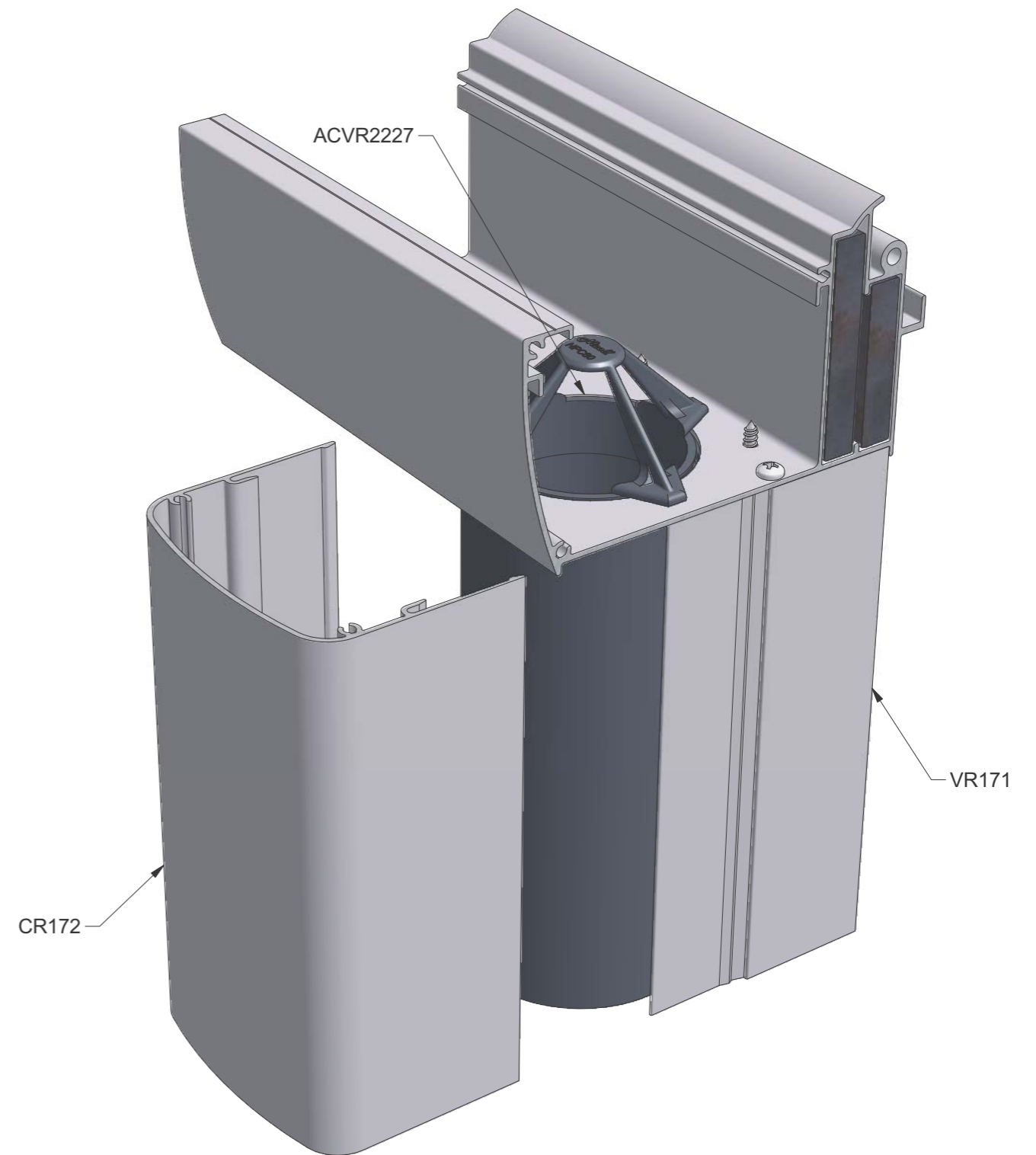
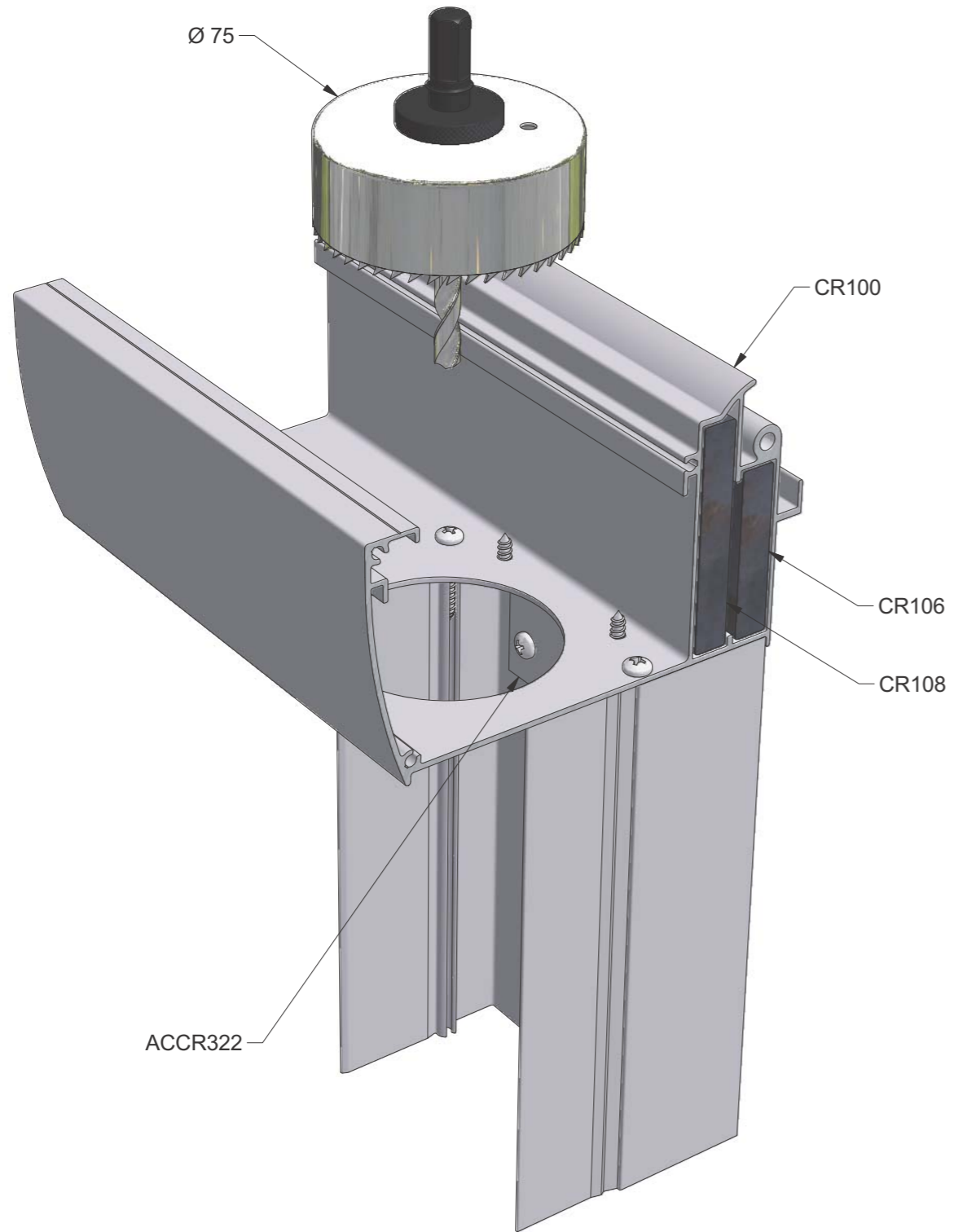

Montage ACVR2227.idw

MONTAGE LIGGER OP GOOT
MONTAGE CHEVRON SUR GOUTTIERE
MONTAGE TRAGER AUF DACHRINNE
MONTAGE ROOF BEAM AT GUTTER

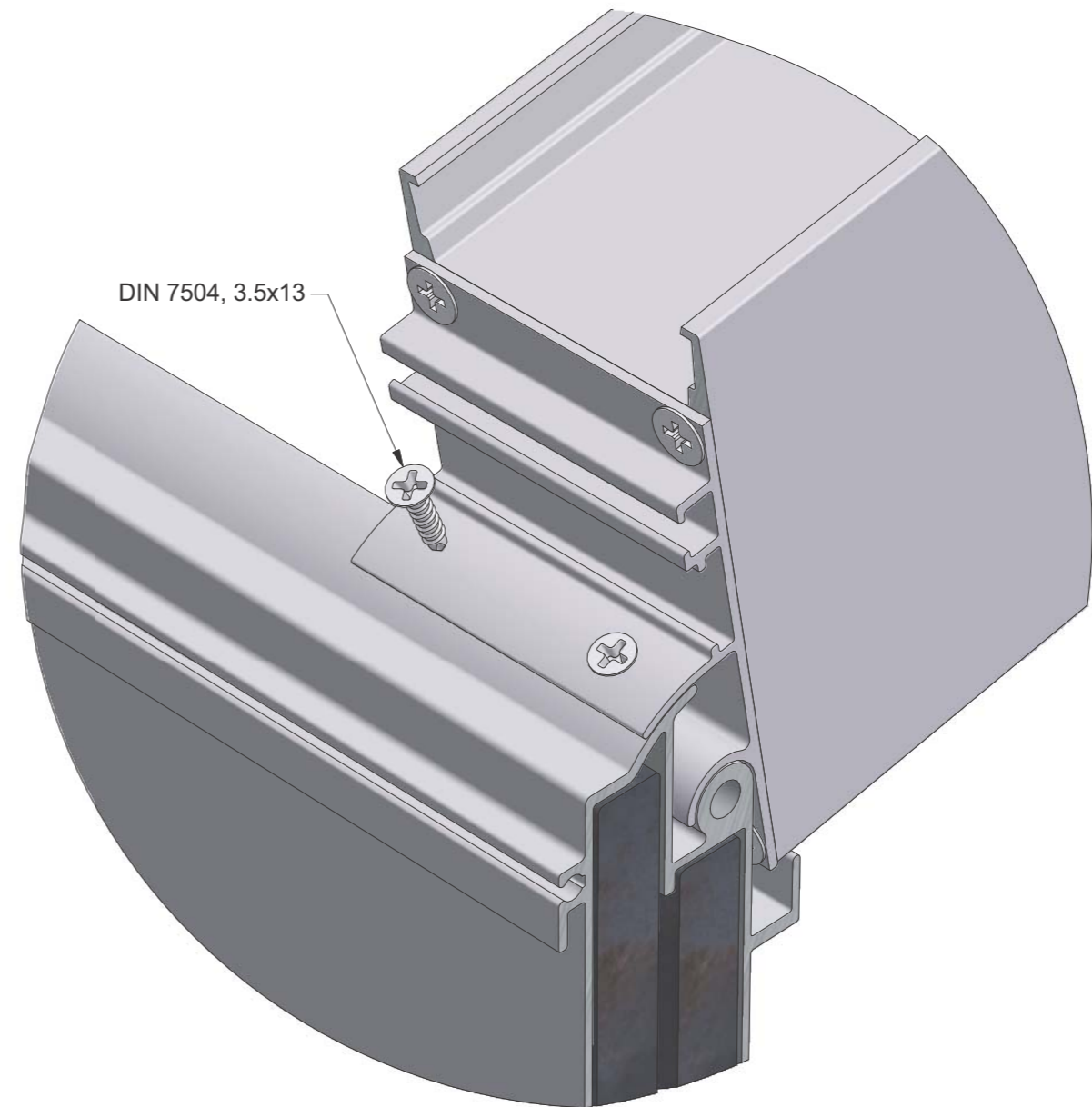
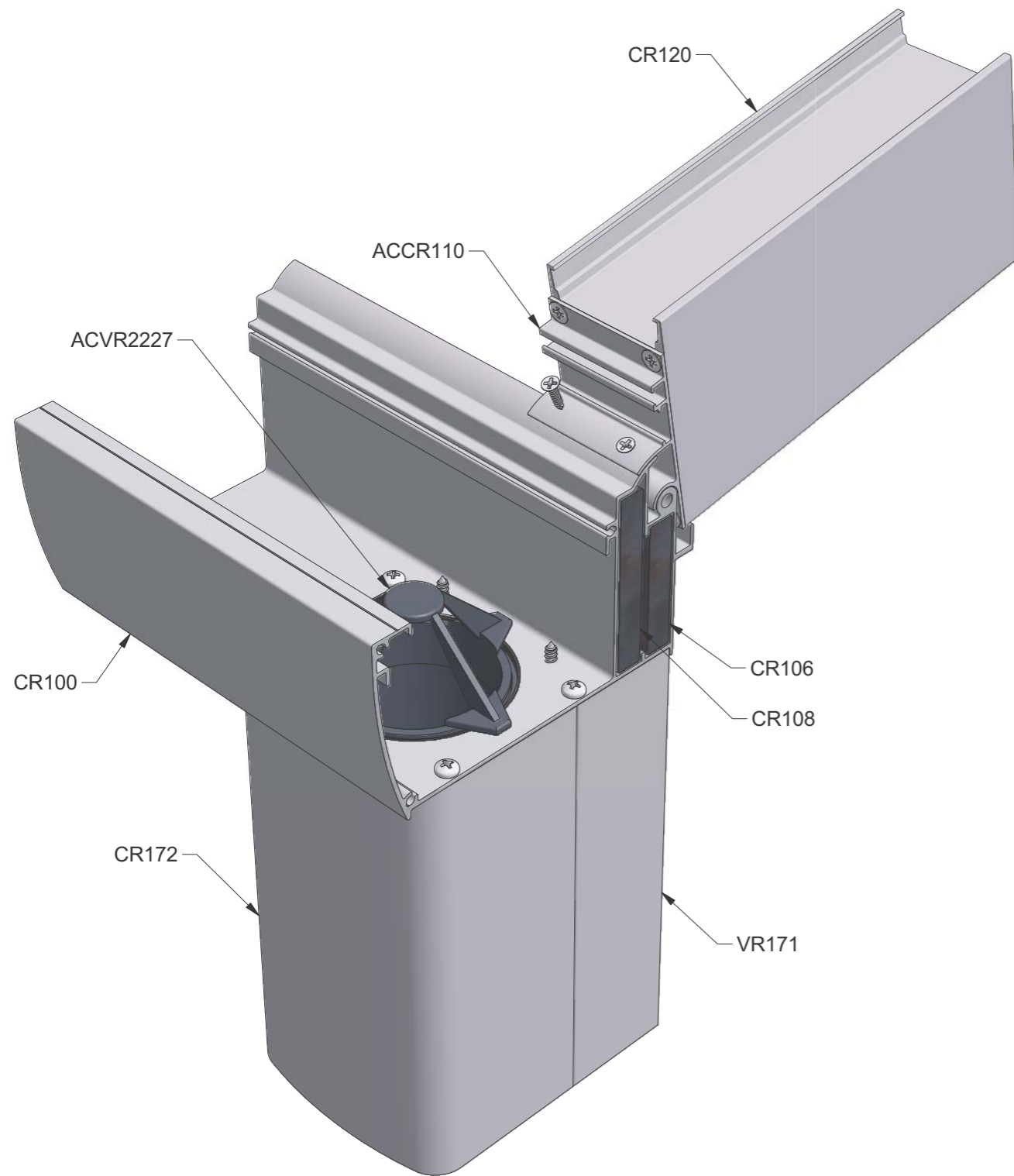

Montage ligger op goot.idw

MONTAGE MUURPROFIELEN
 MONTAGE PROFILS MURAL
 MONTAGE MAUERPROFIELEN
 MONTAGE WALL PROFILES

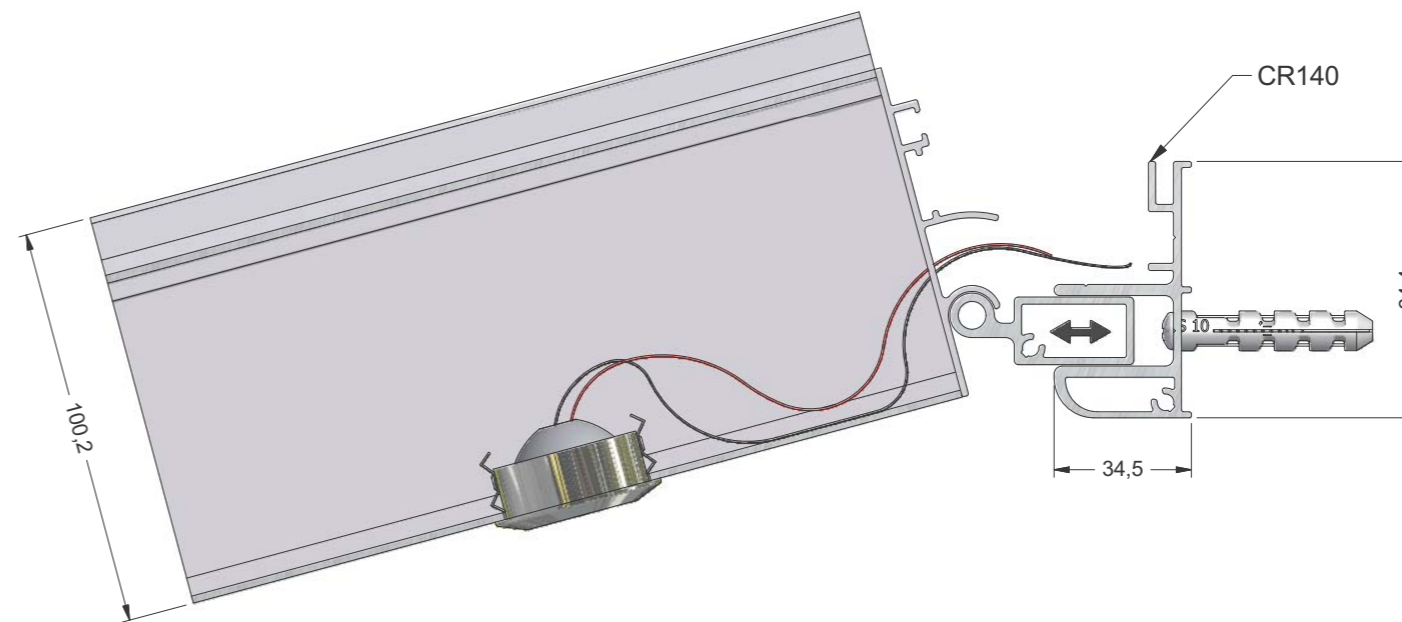
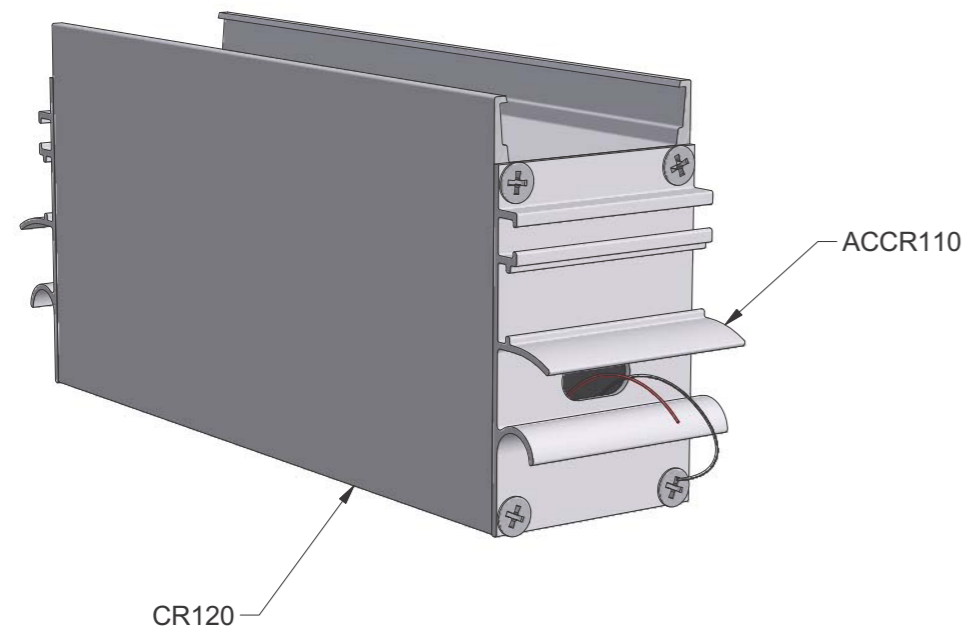
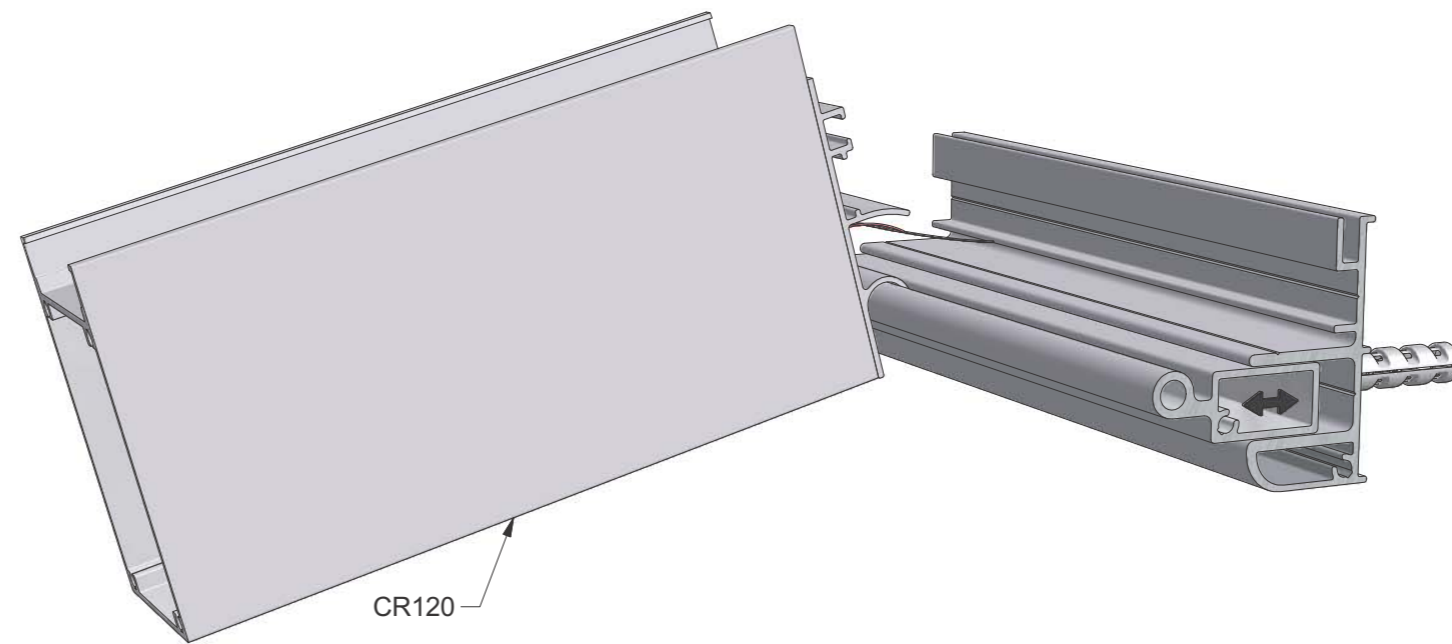

Montage muurprof.idw

MONTAGE ACCR140
MONTAGE ACCR140
MONTAGE ACCR140
MONTAGE ACCR140

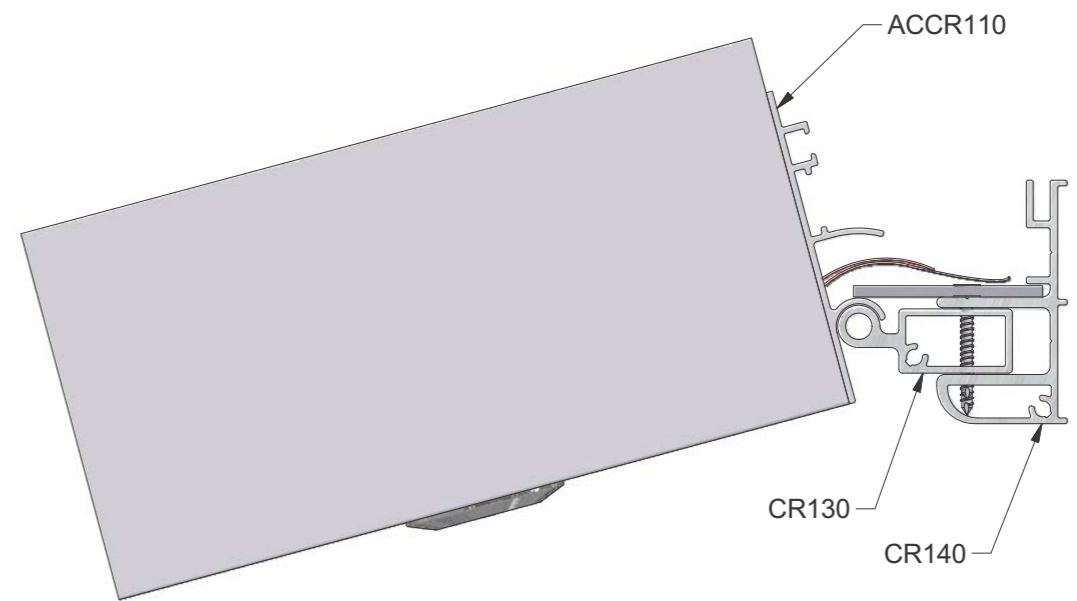
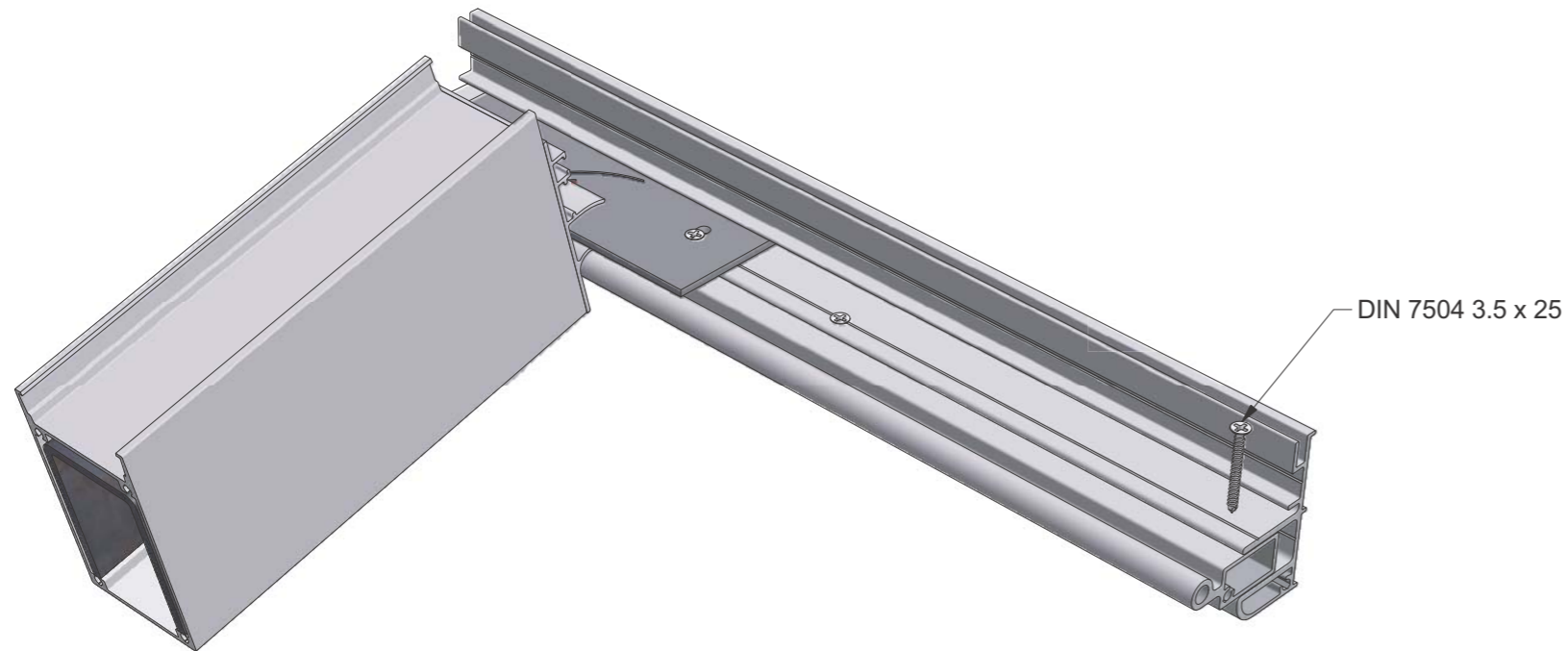
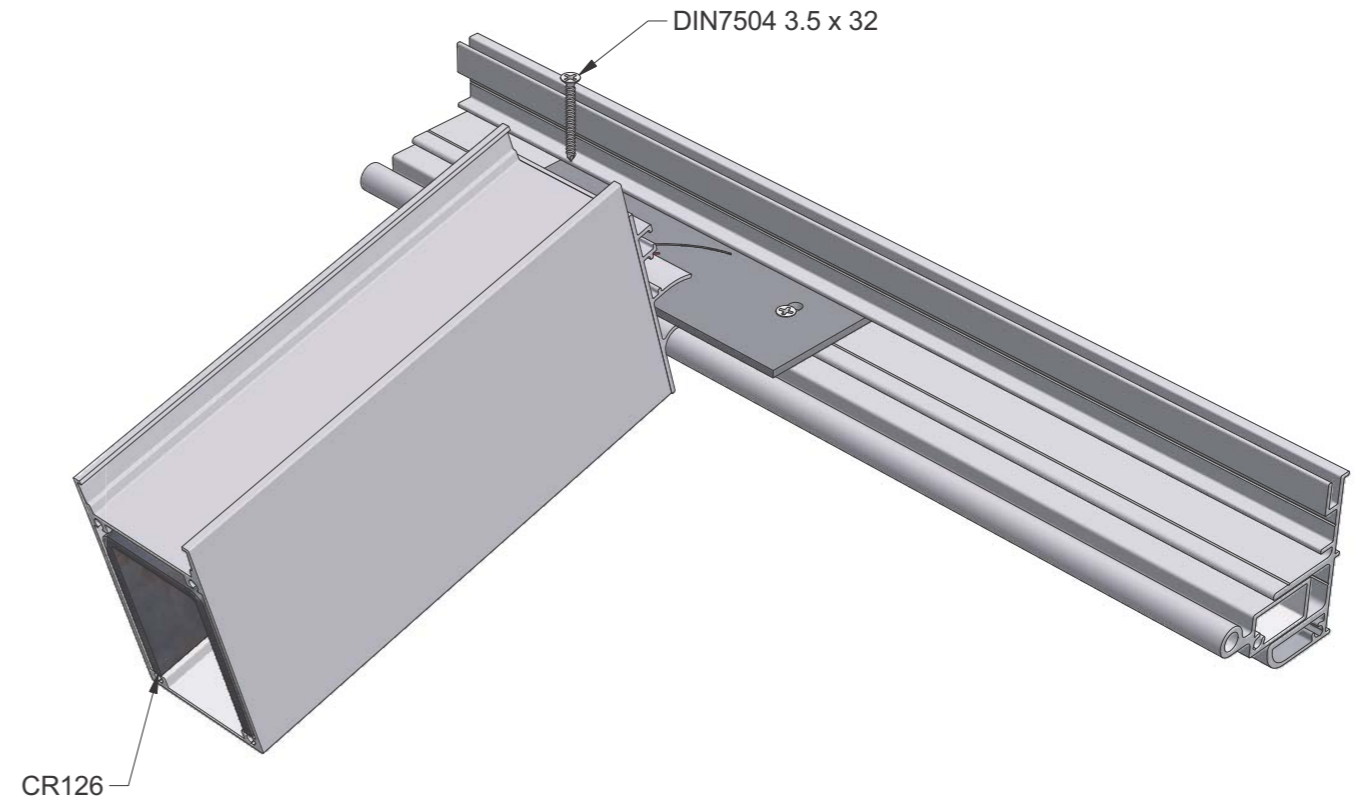
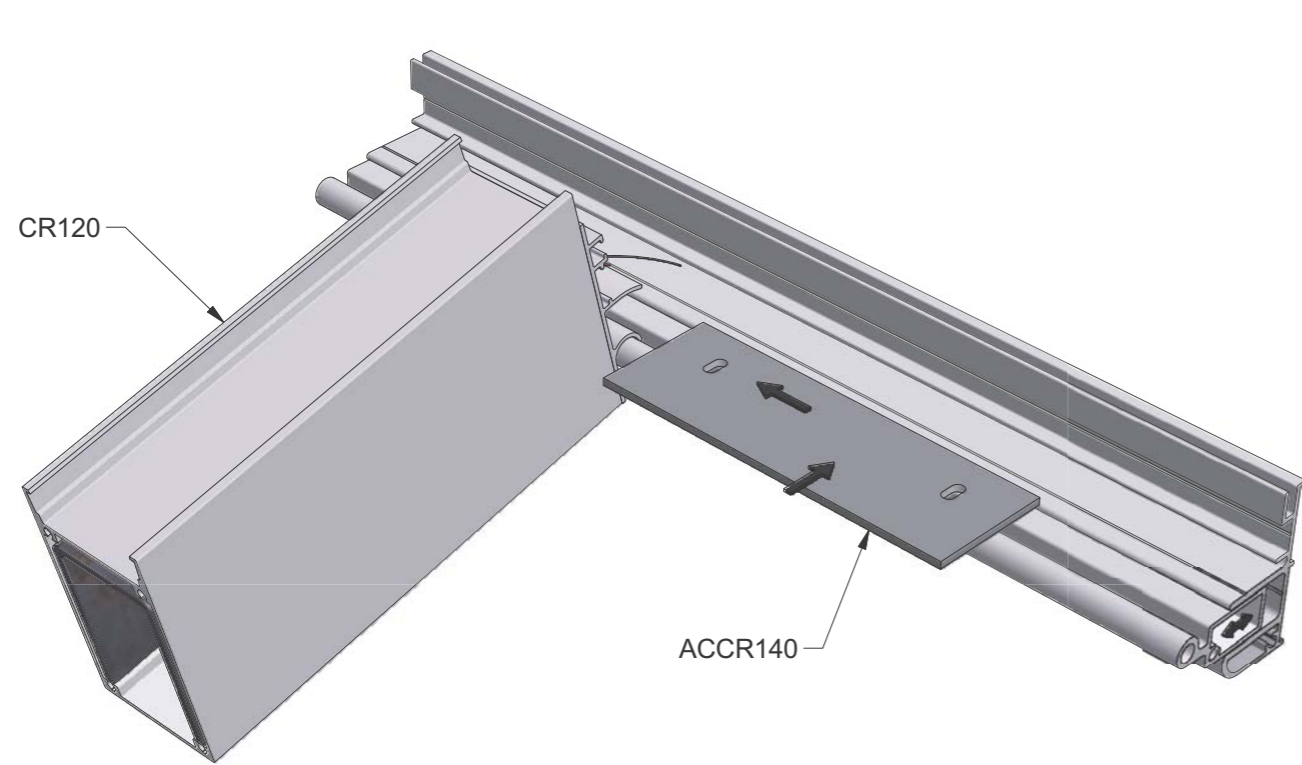

MONTAGE VR515
MONTAGE VR515
MONTAGE VR515
MONTAGE VR515

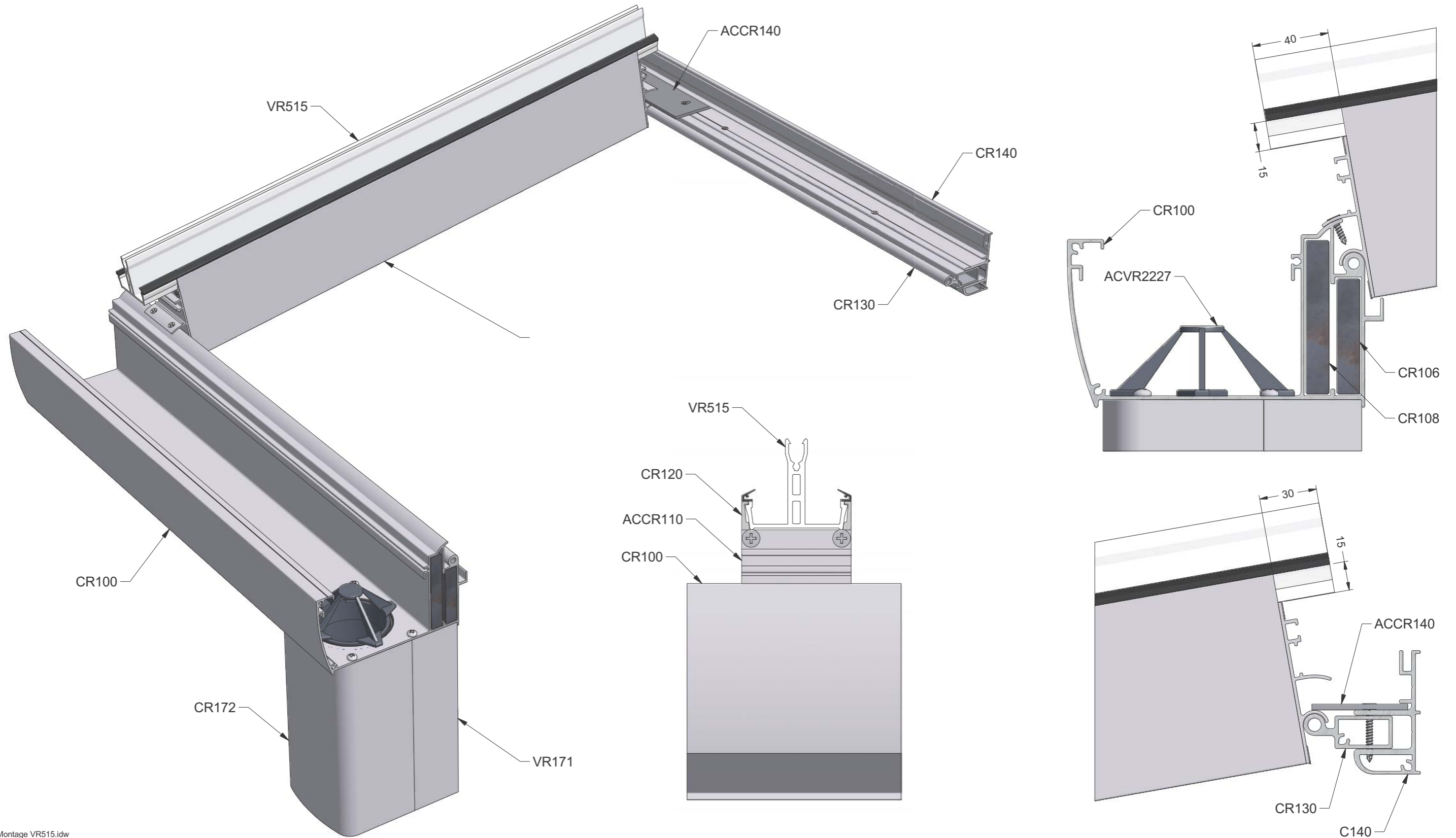

Montage VR515.idw

MONTAGE SCHARNIERPROFIEL
 MONTAGE PROFIL DE CHARNIERE
 MONTAGE SCHARNIERPROFIL
 MONTAGE HINGE PROFILE

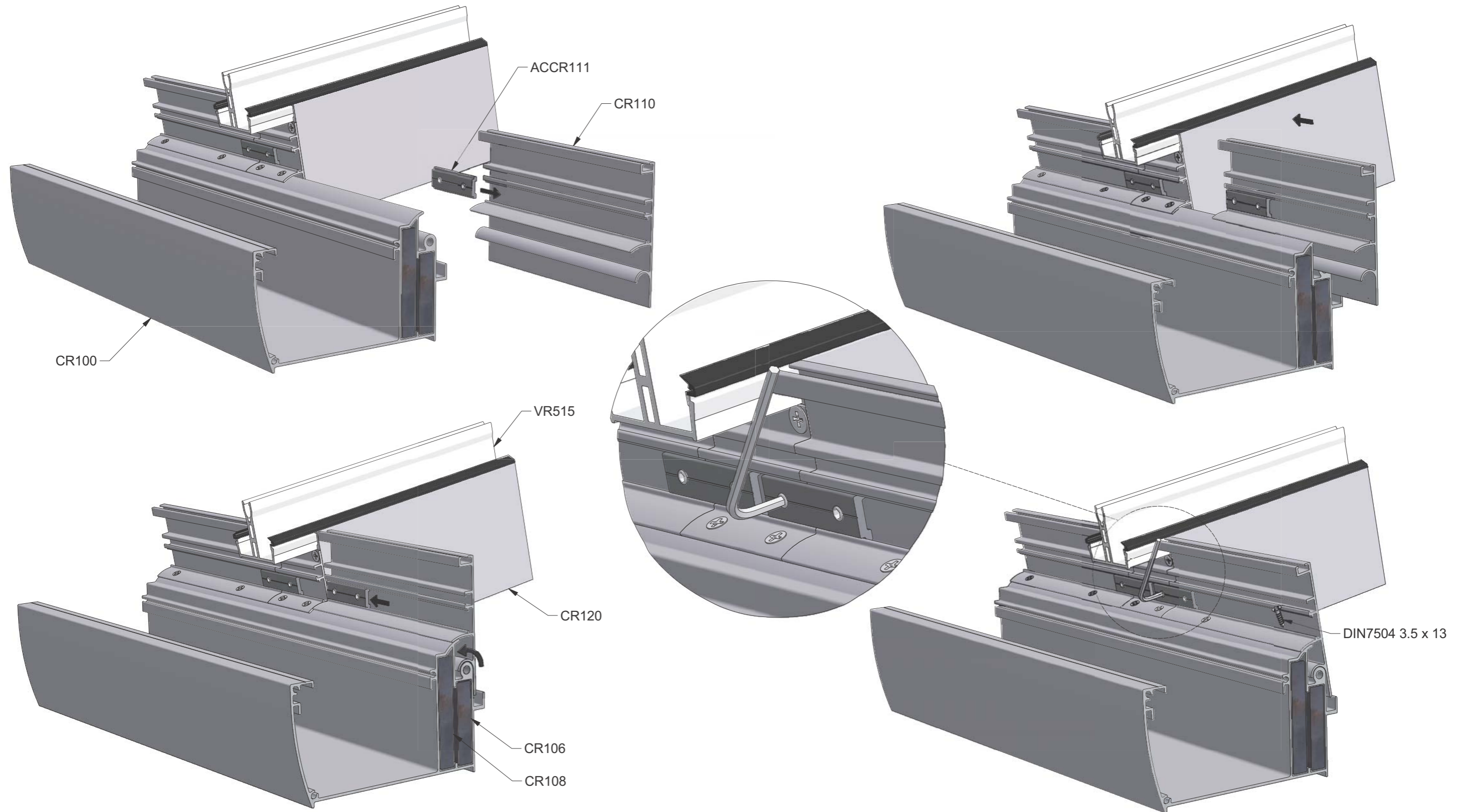

Montage scharnierprofil.idw

MONTAGE SCHARNIERPROFIEL
 MONTAGE PROFIL DE CHARNIERE
 MONTAGE SCHARNIERPROFIEL
 MONTAGE HINGE PROFILE

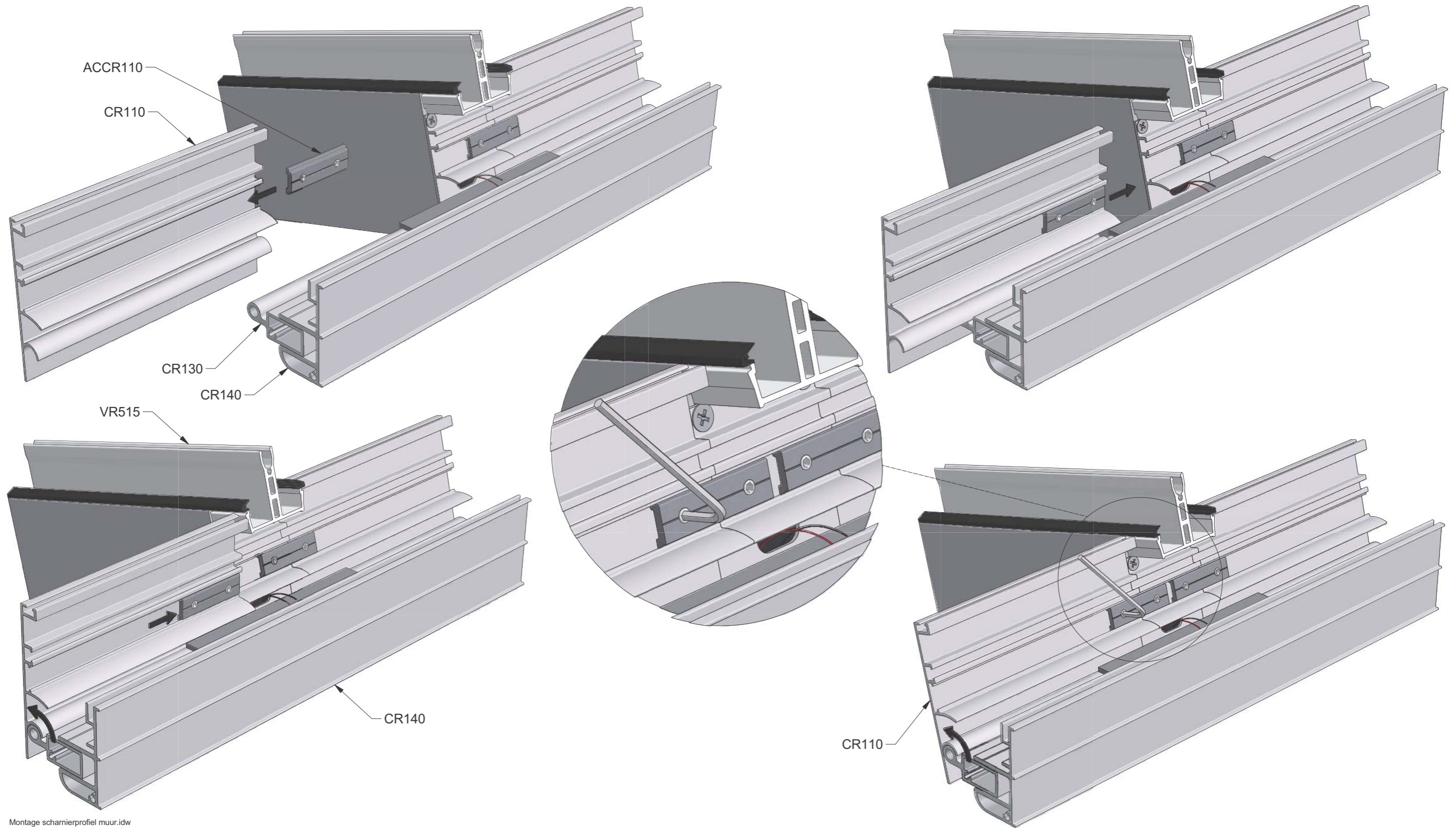

Montage scharnierprofil muur.idw

WERKTEKENINGEN - DESSINS DE CONSTRUCTION - KONSTRUKTIONZEICHNUNGEN - CONSTRUCTION DRAWINGS

MONTAGE VR040
MONTAGE VR040
MONTAGE VR040
MONTAGE VR040

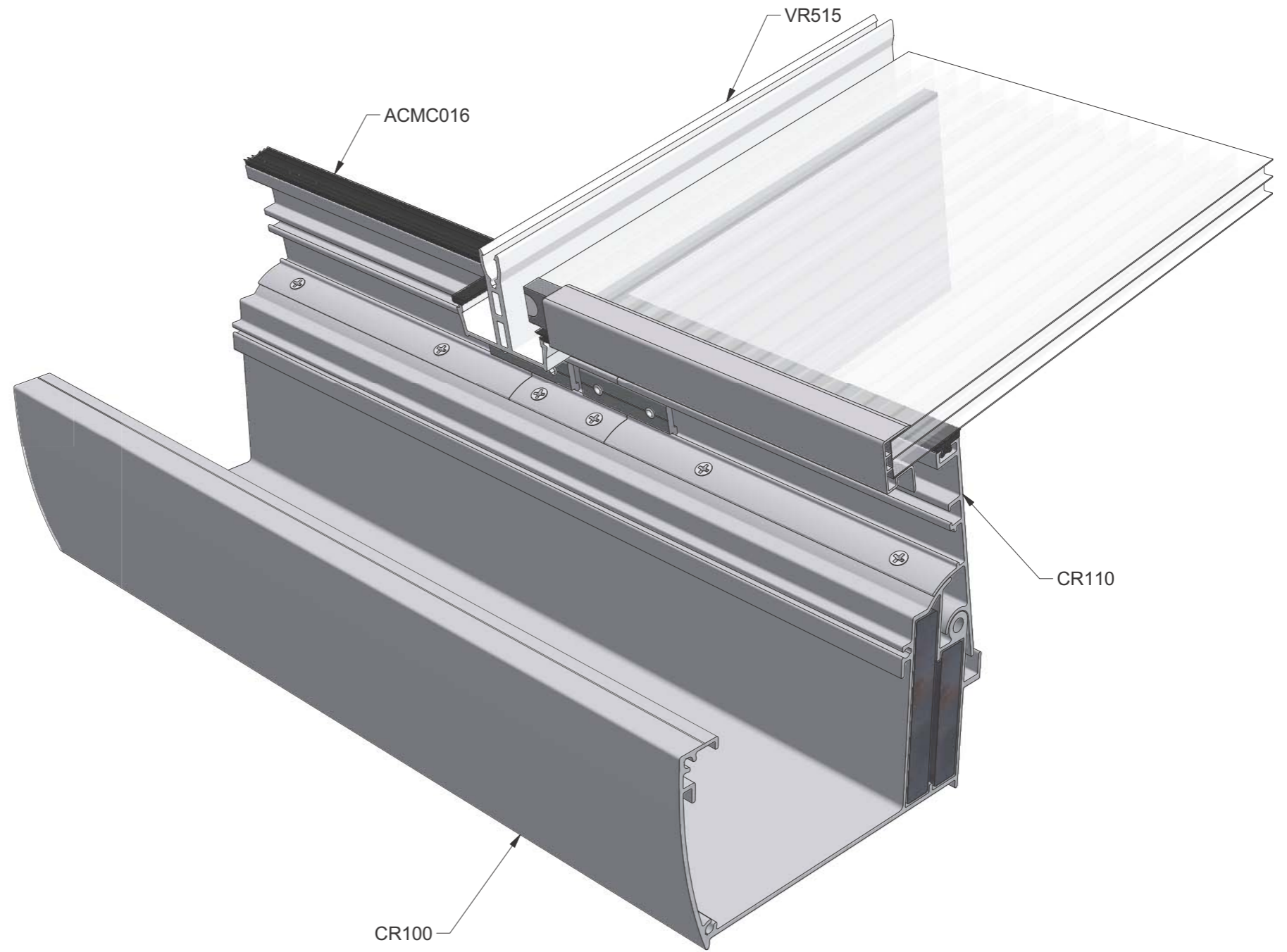
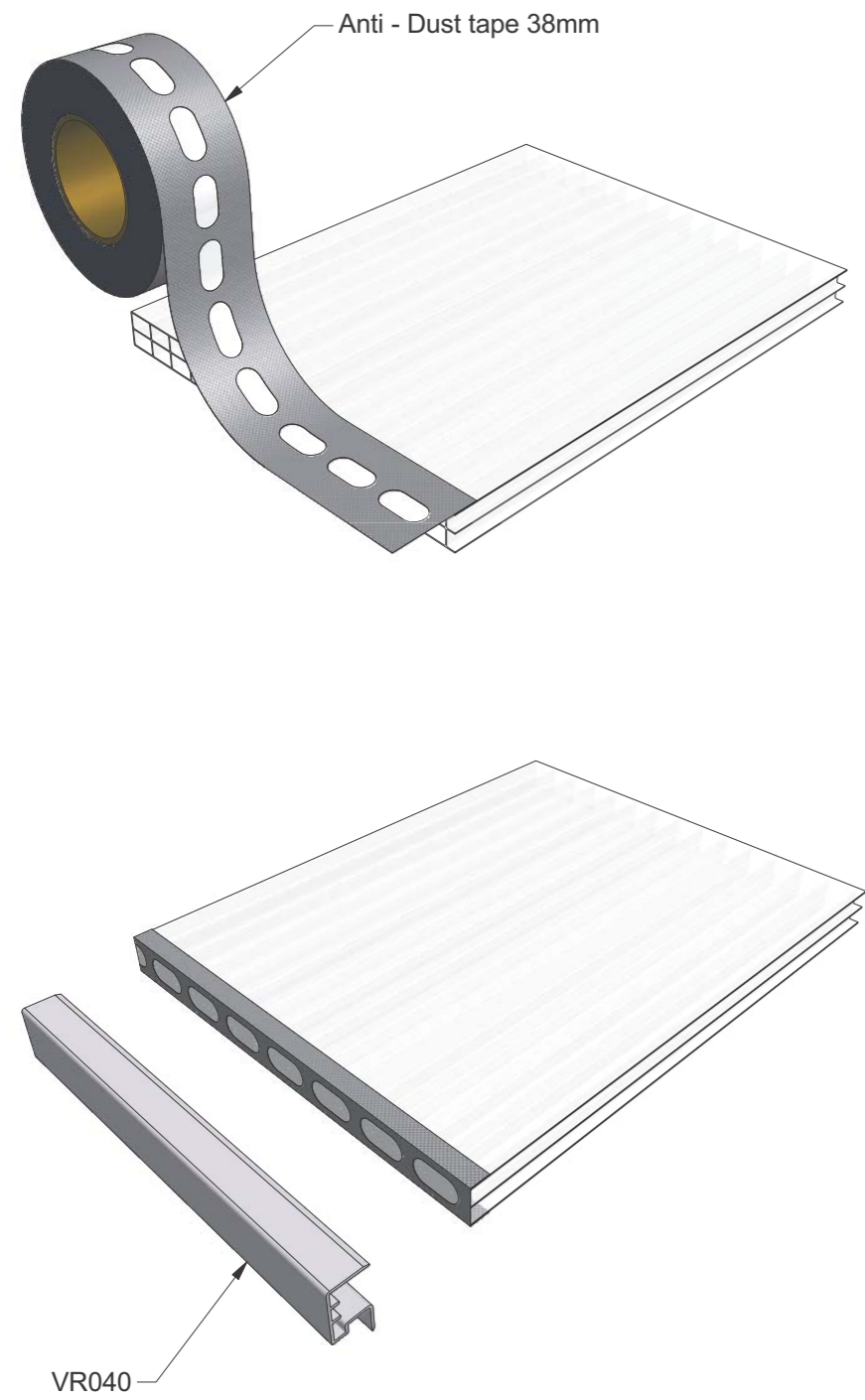

MONTAGE POLYCARBONAAT
MONTAGE POLYCARBONAT
MONTAGE POLYCARBONAT
MONTAGE POLYCARBONATE

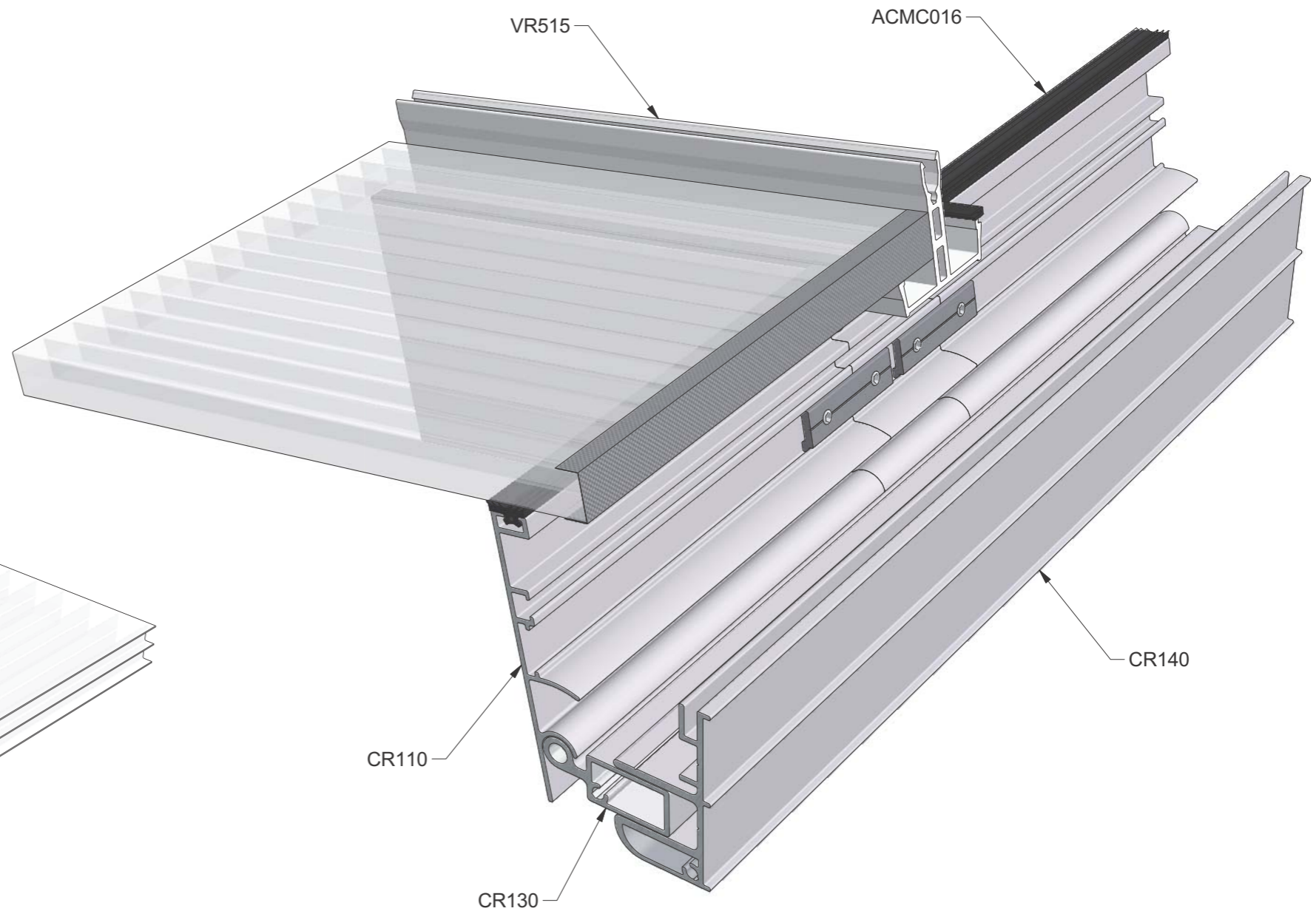
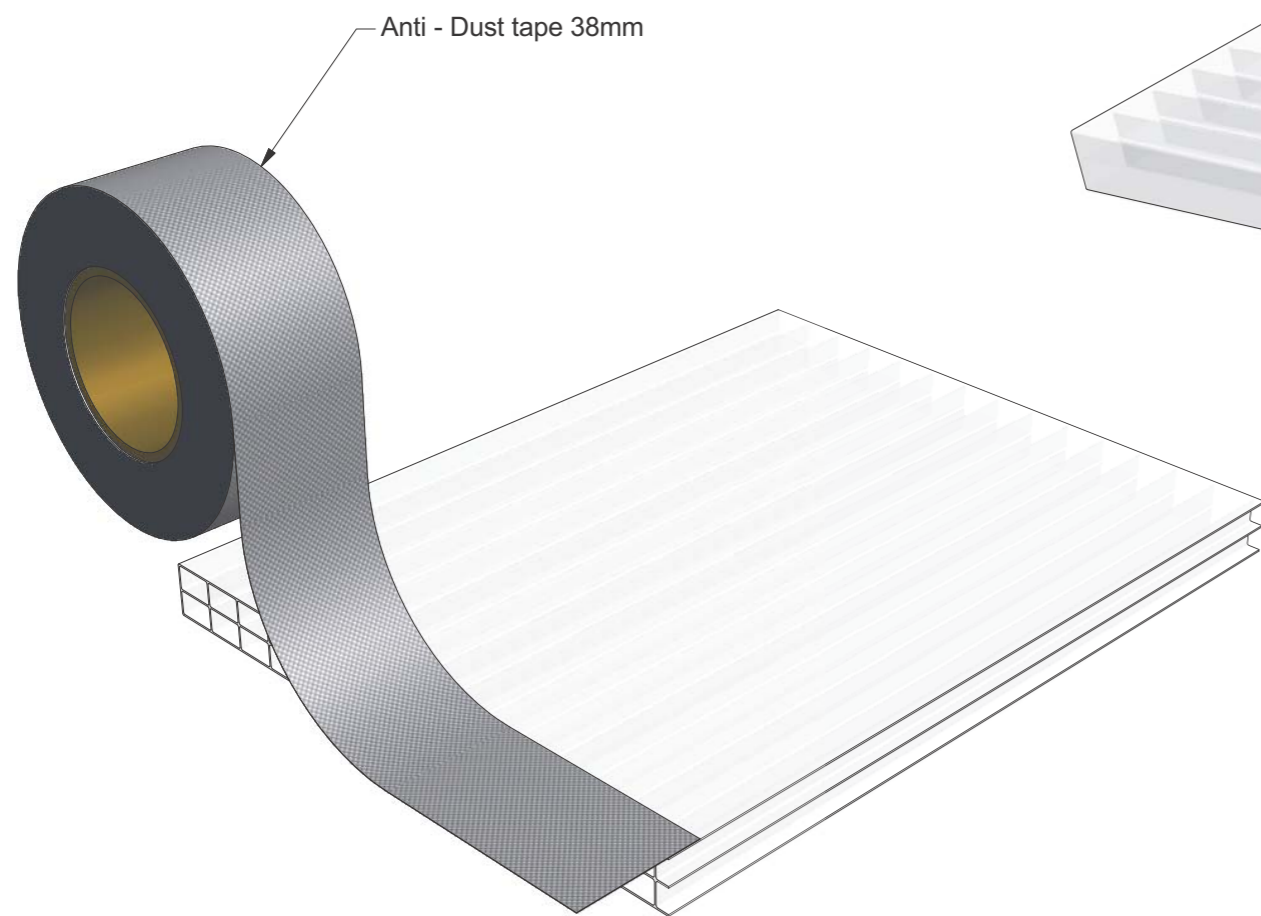

polycarbonaat 2.idw

MONTAGE ALU KLIPS
 MONTAGE CLIPS ALU
 MONTAGE ALU KLIPSE
 MONTAGE ALU CLIPS

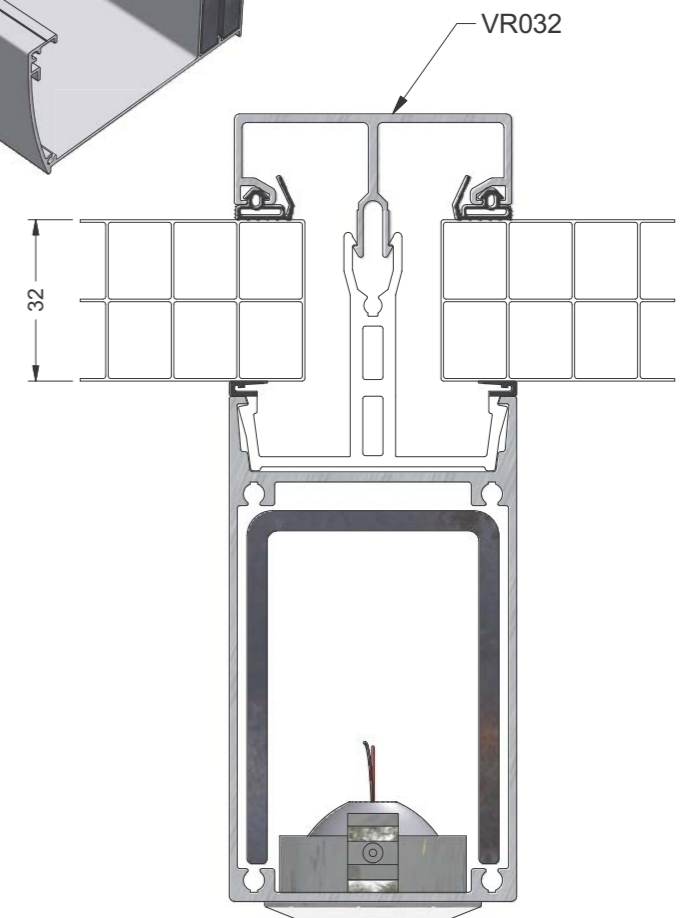
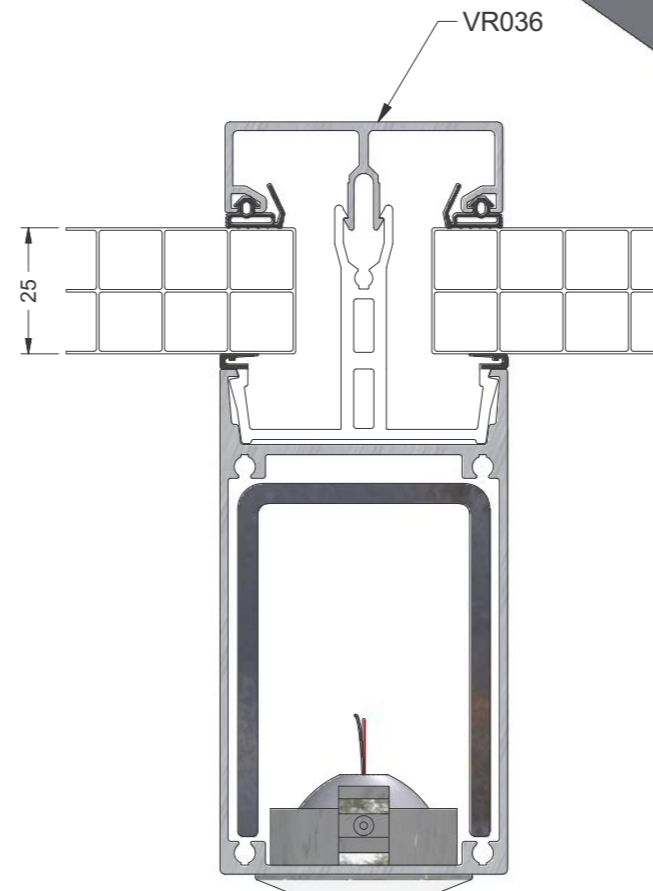
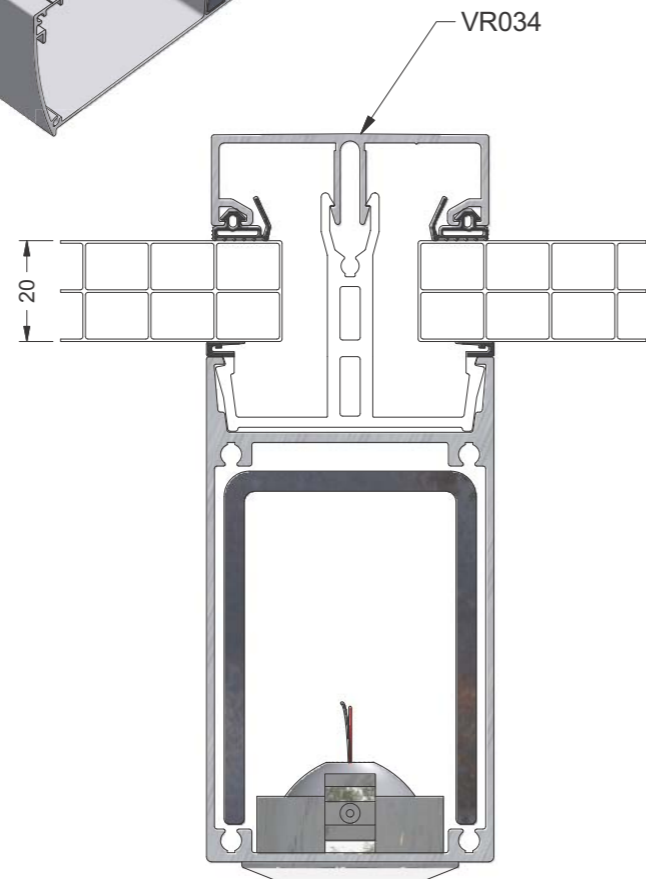
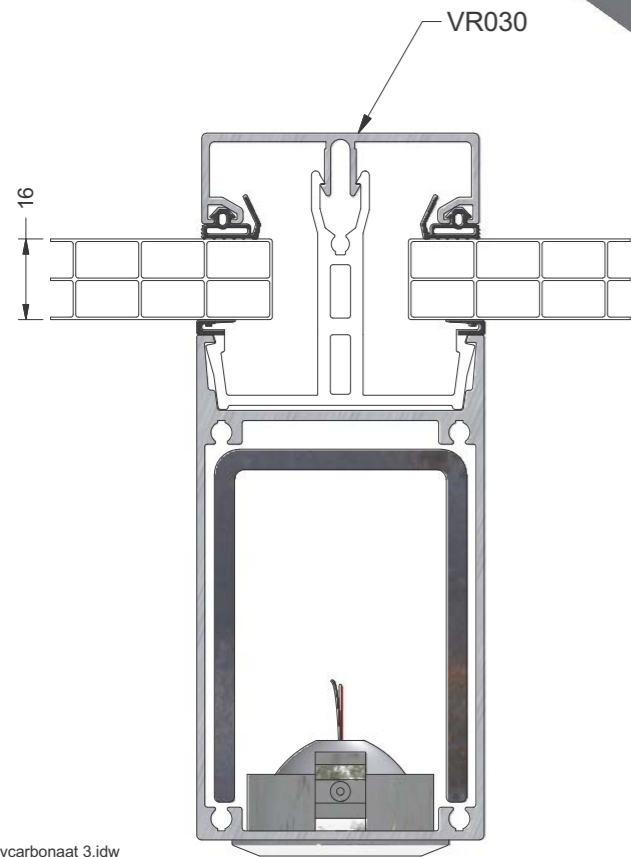
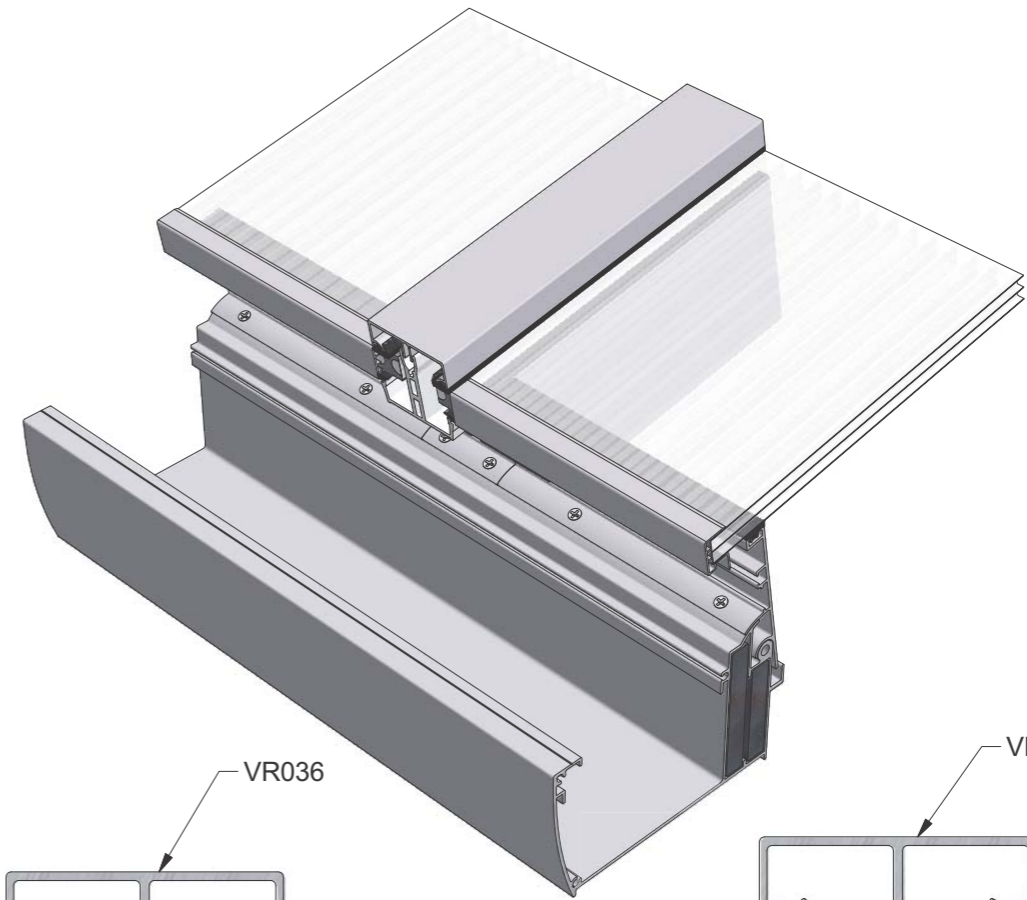
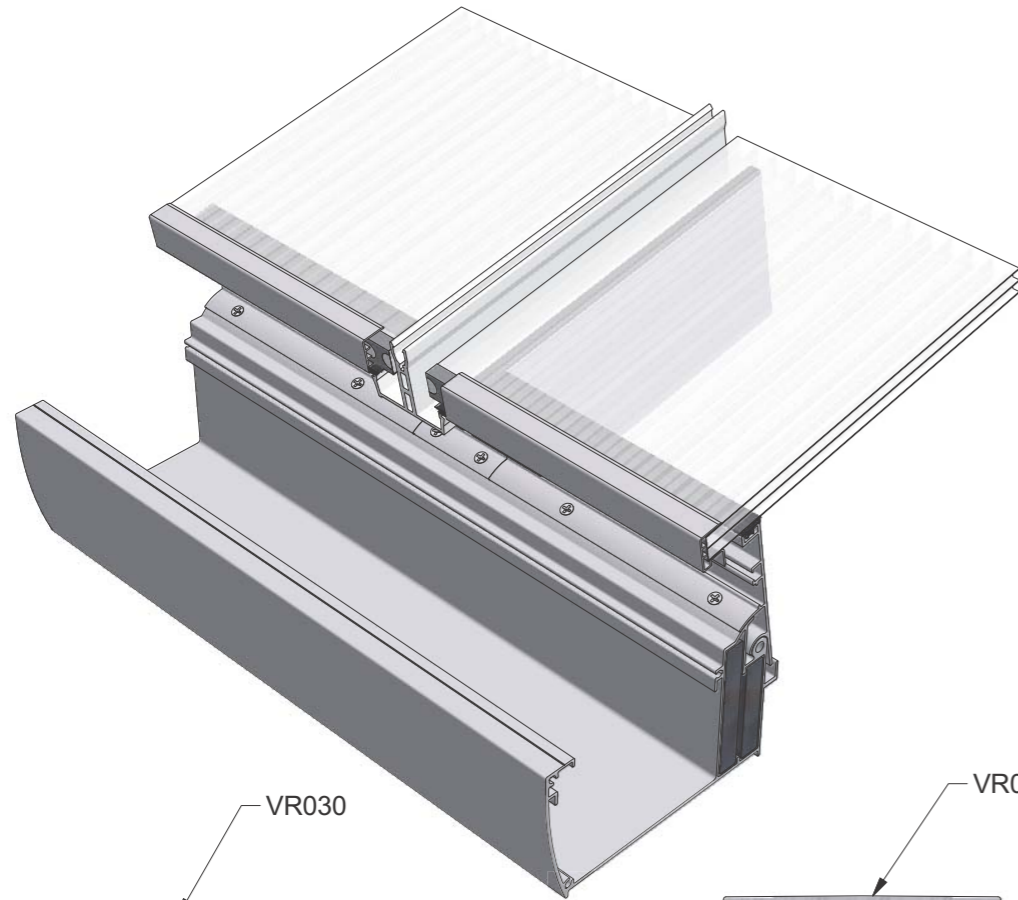

polycarbonaat 3.idw

MONTAGE ALU KLIPS
 MONTAGE CLIPS ALU
 MONTAGE ALU KLIPSE
 MONTAGE ALU CLIPS

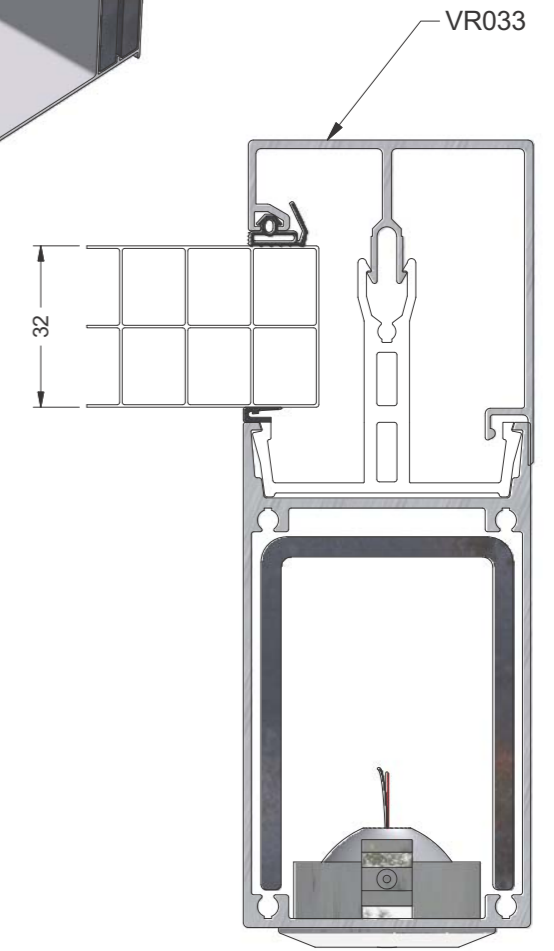
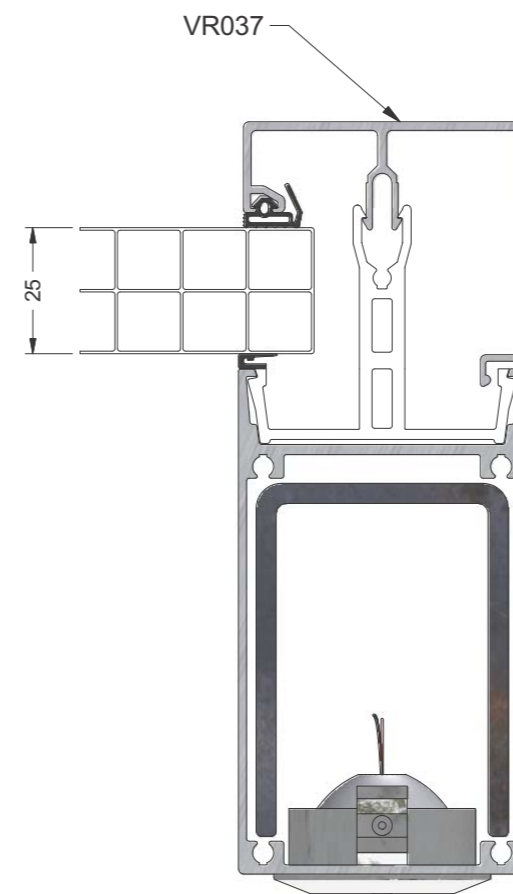
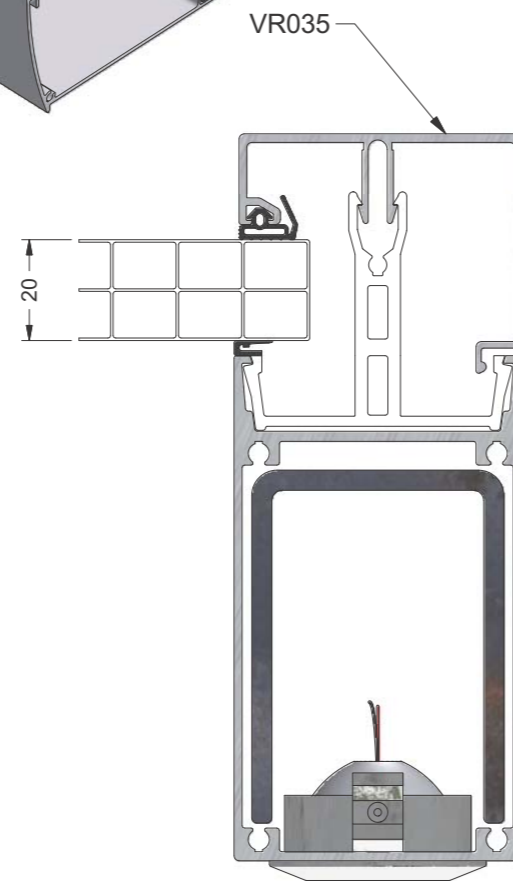
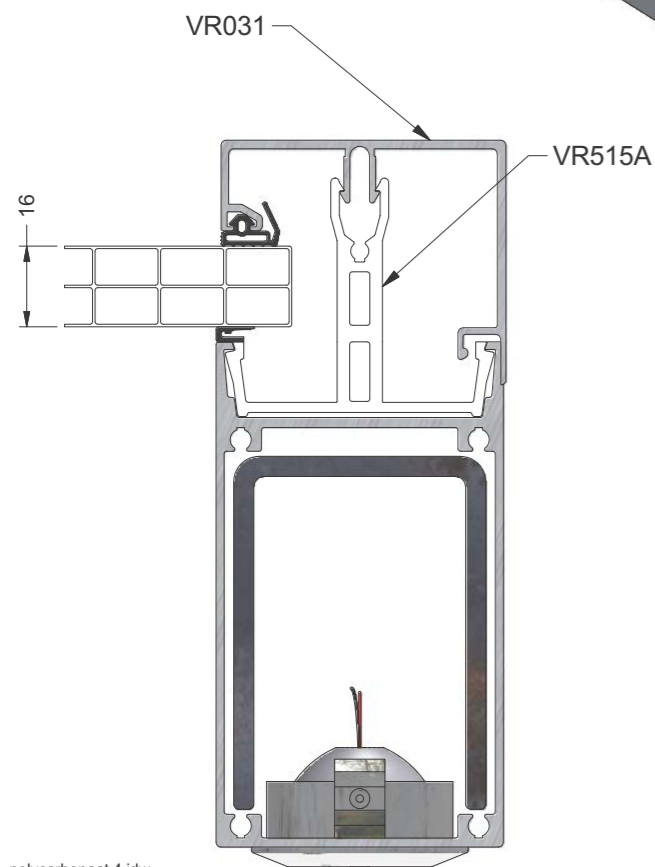
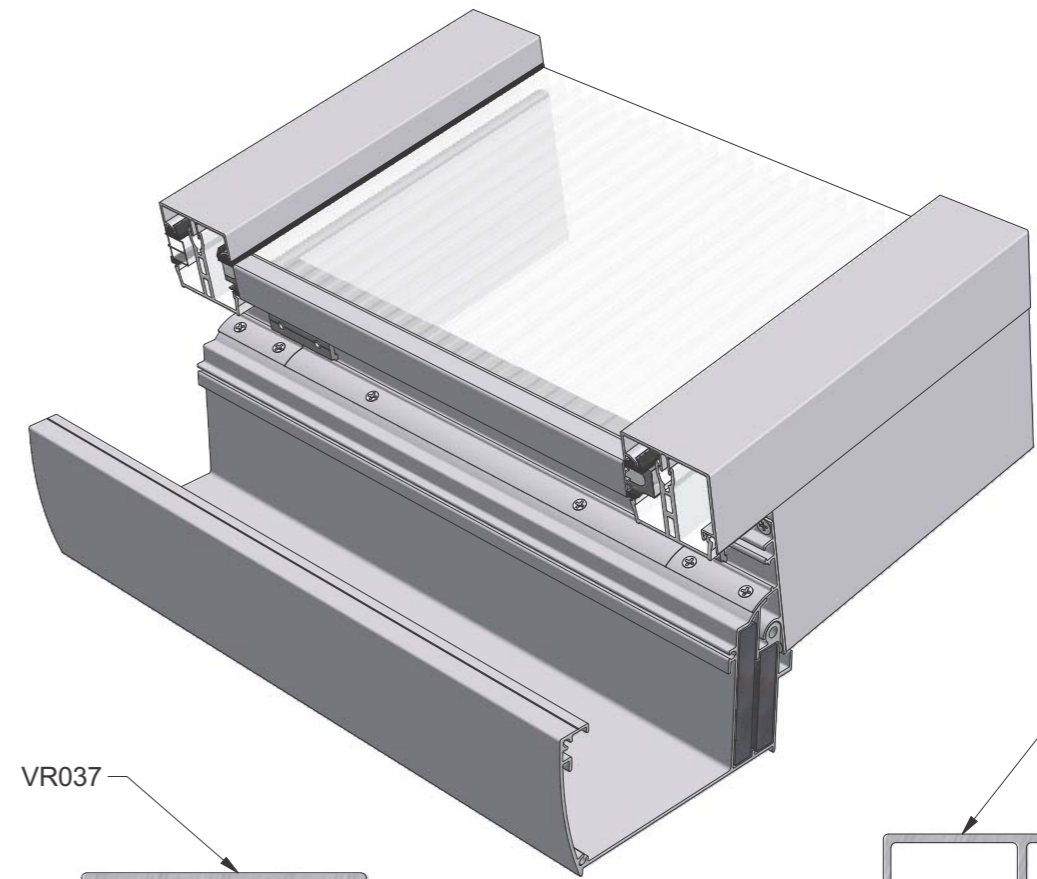
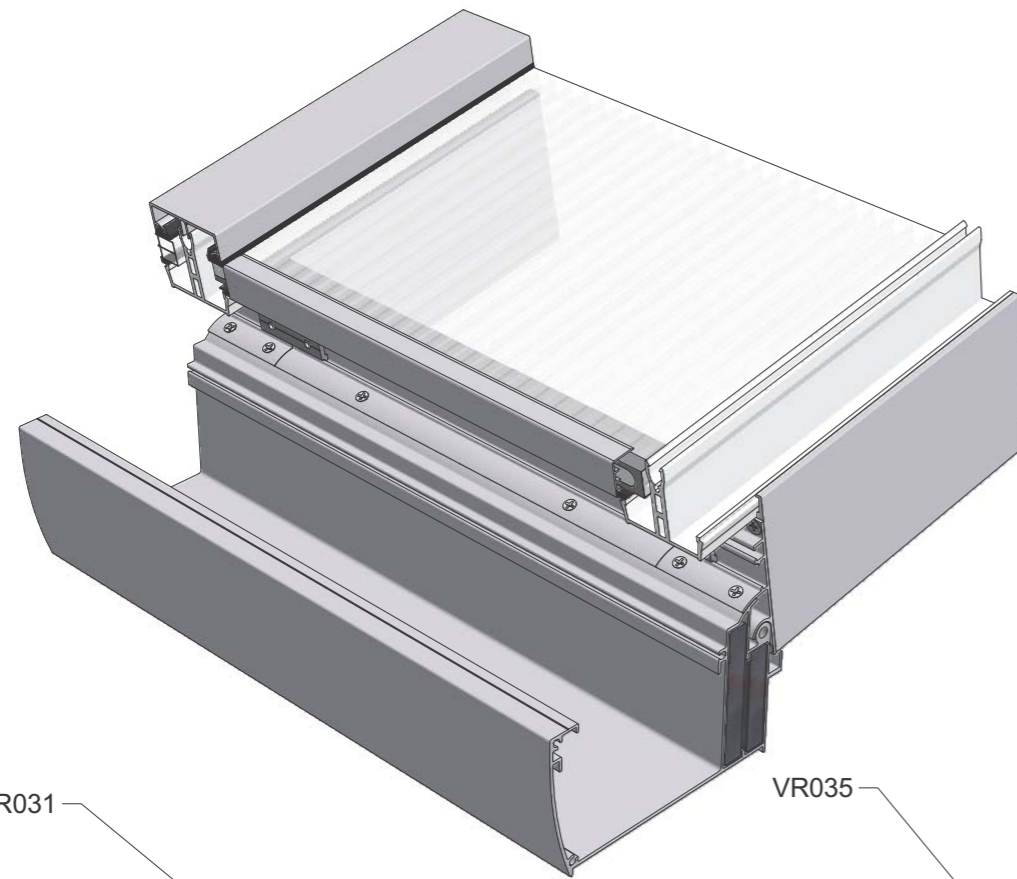

polycarbonaat 4.idw

MONTAGE ACCR112
MONTAGE ACCR112
MONTAGE ACCR112
MONTAGE ACCR112

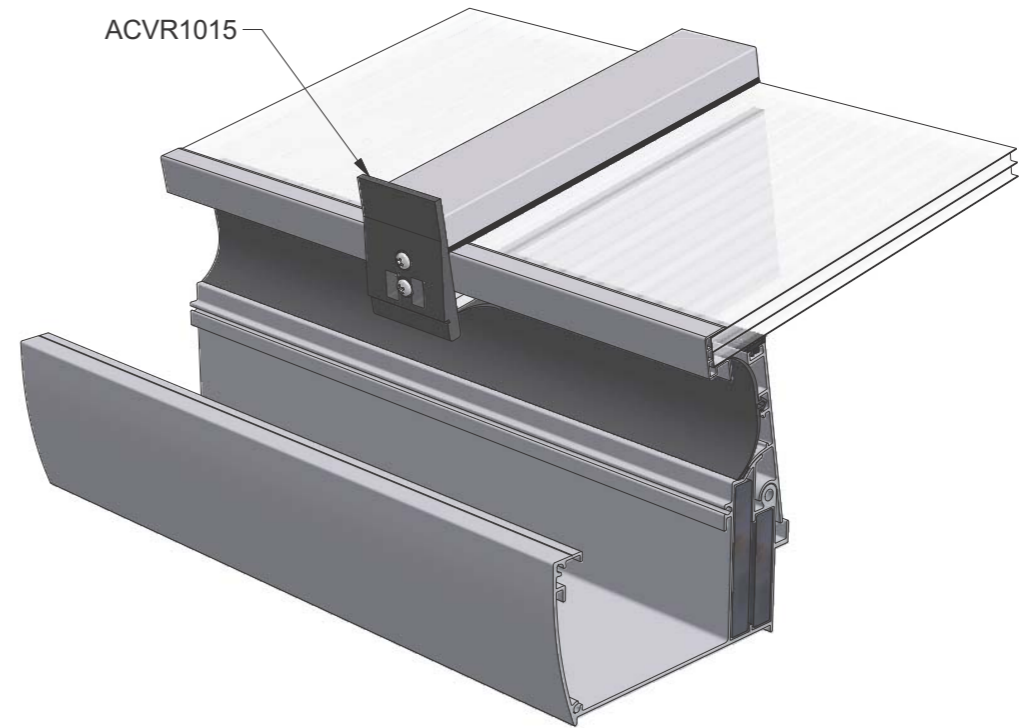
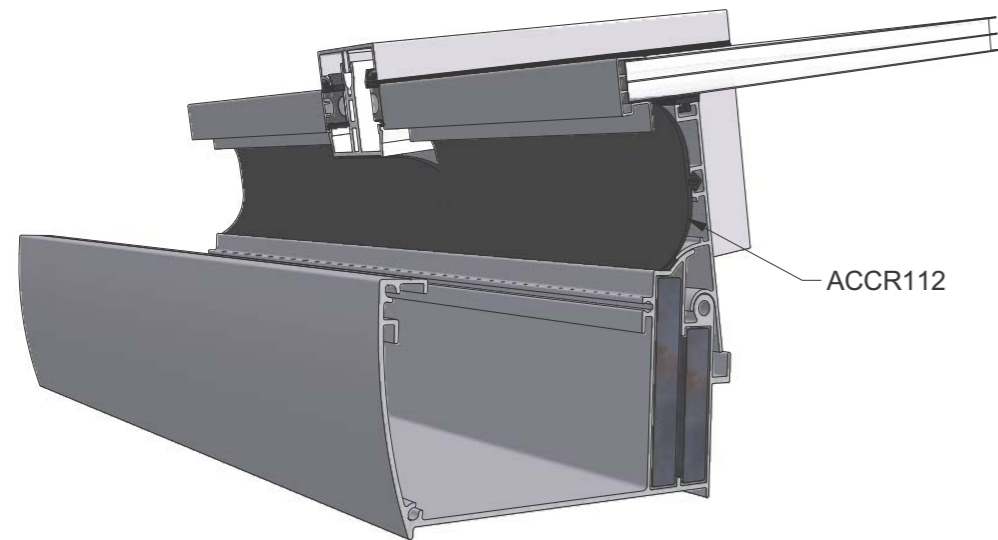
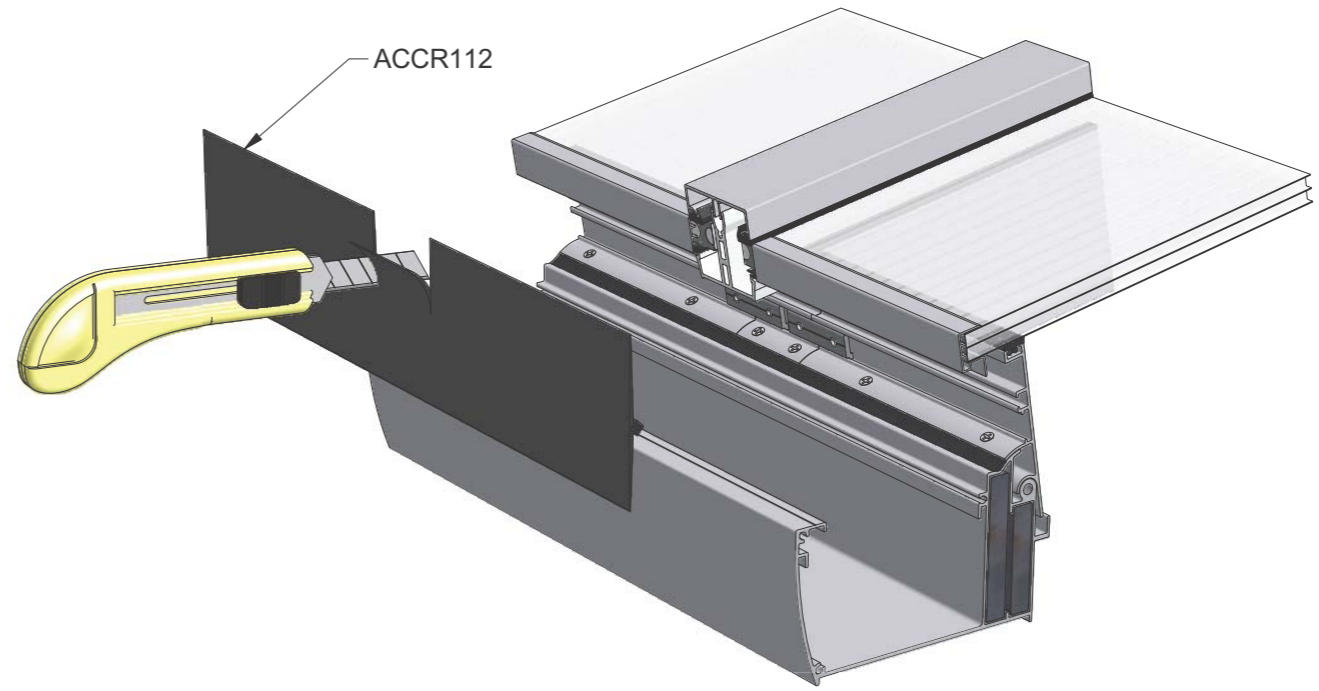
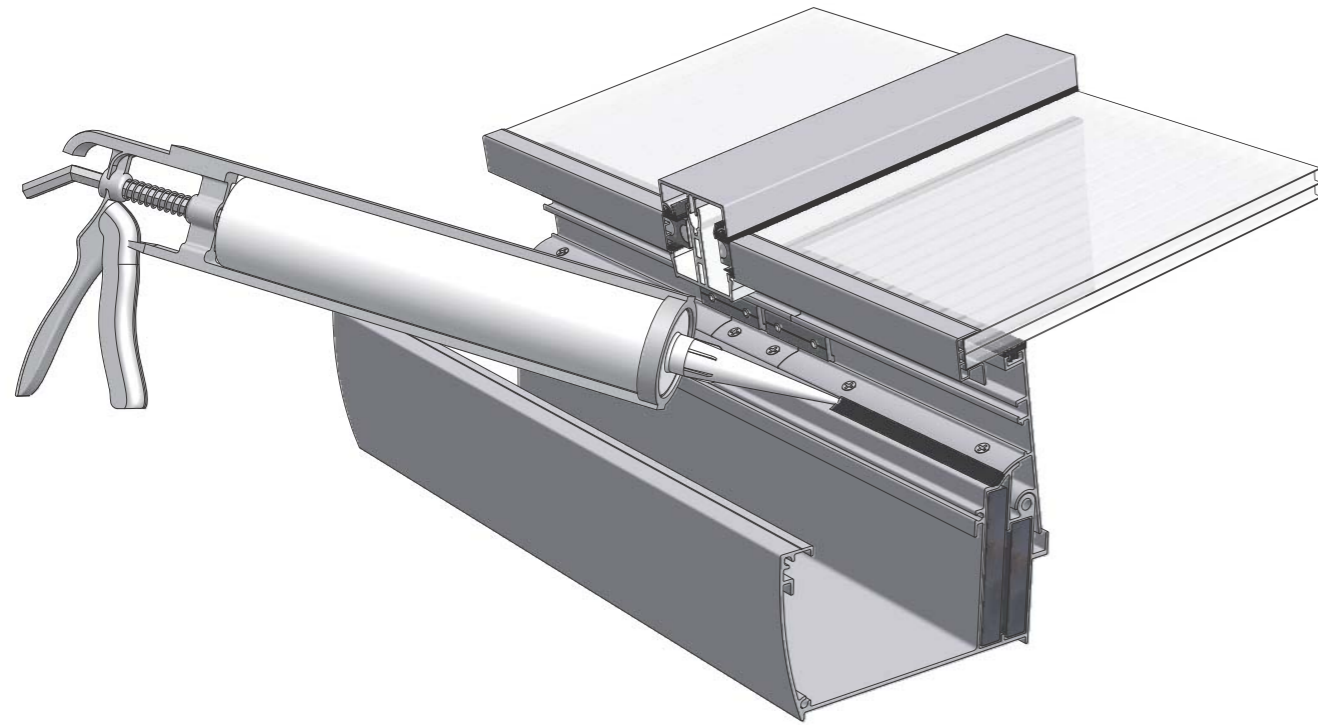

montage ACCR112.idw

MONTAGE CR150
MONTAGE CR150
MONTAGE CR150
MONTAGE CR150

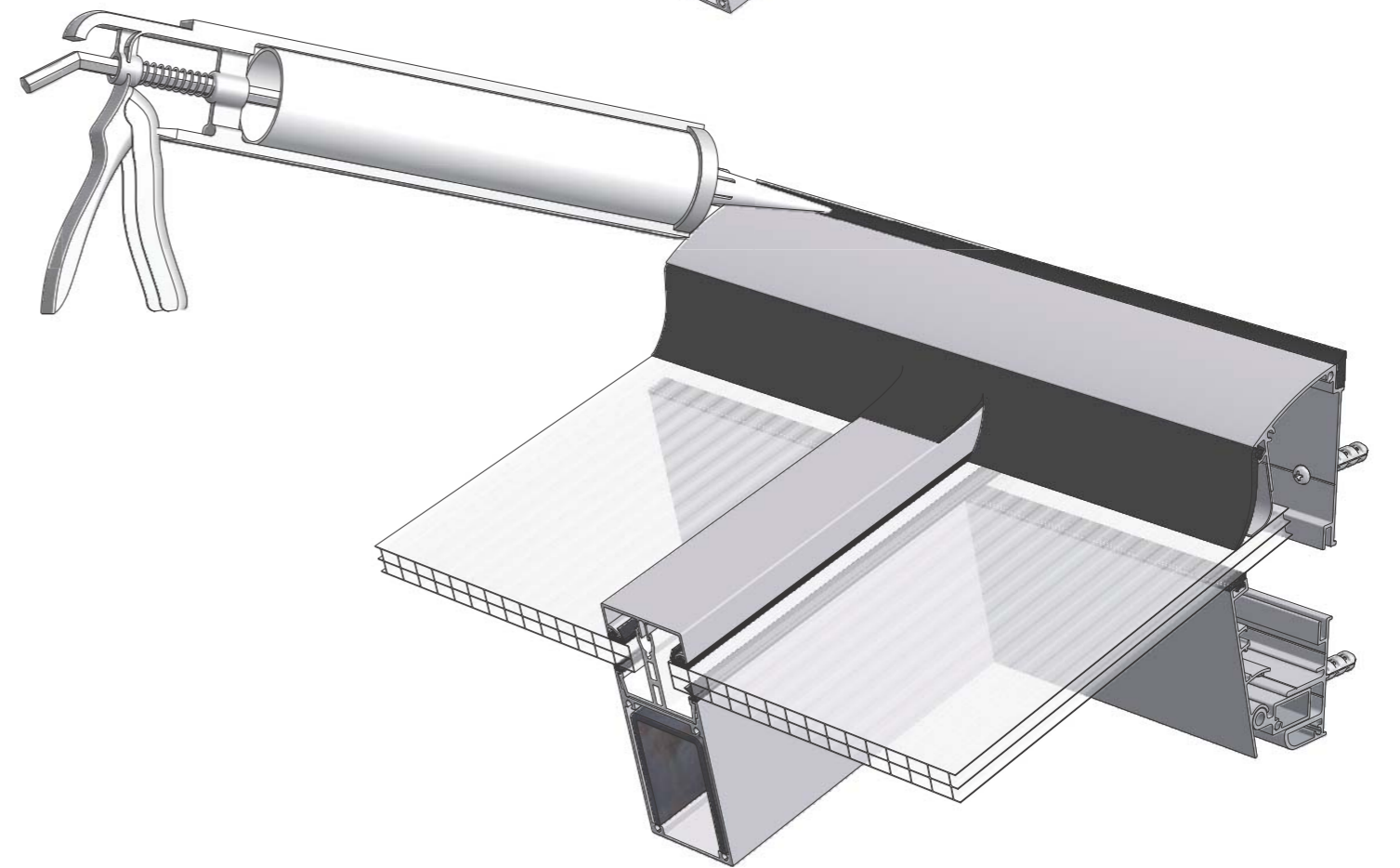
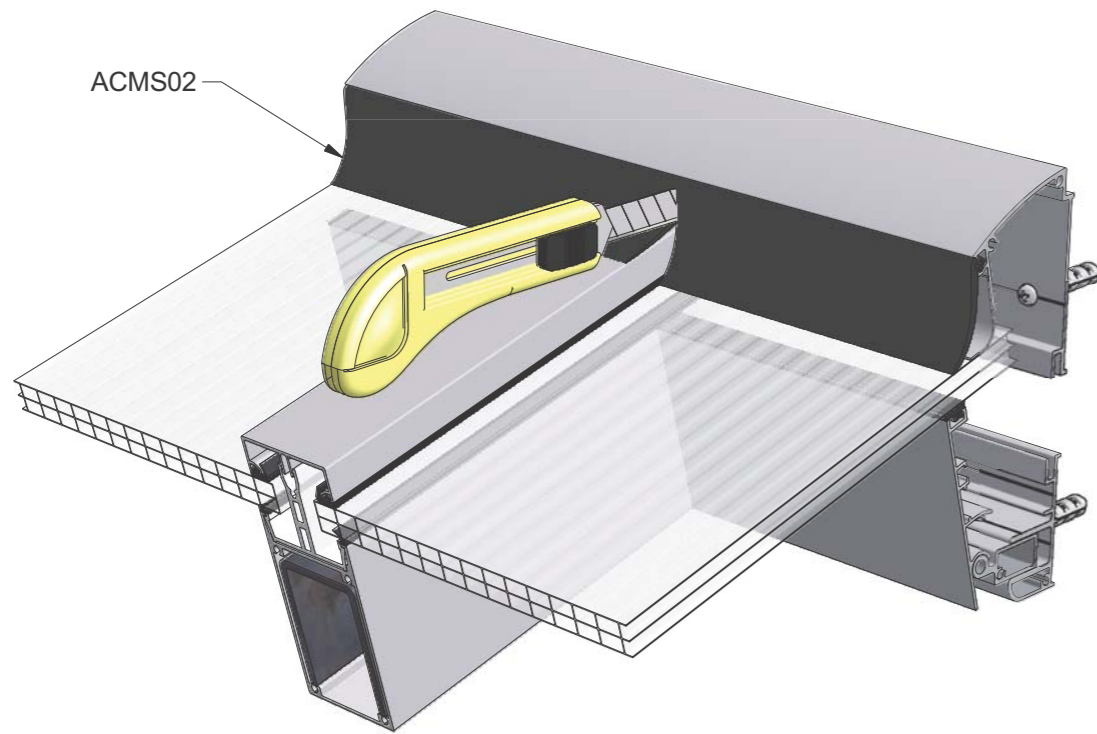
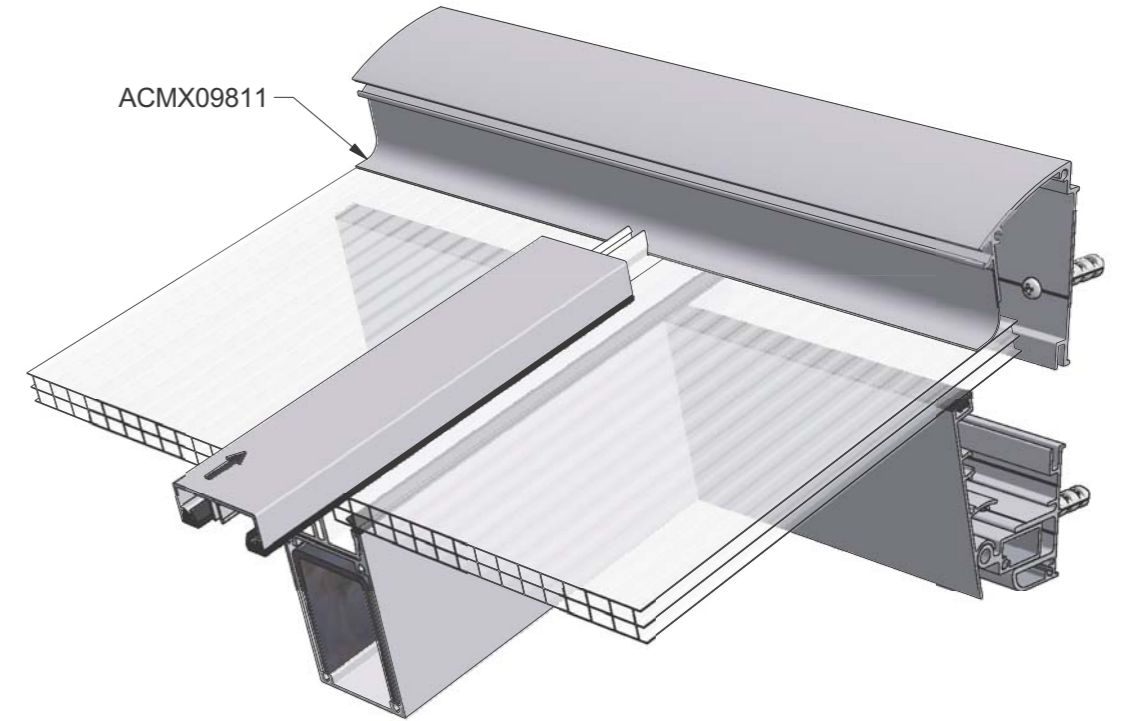
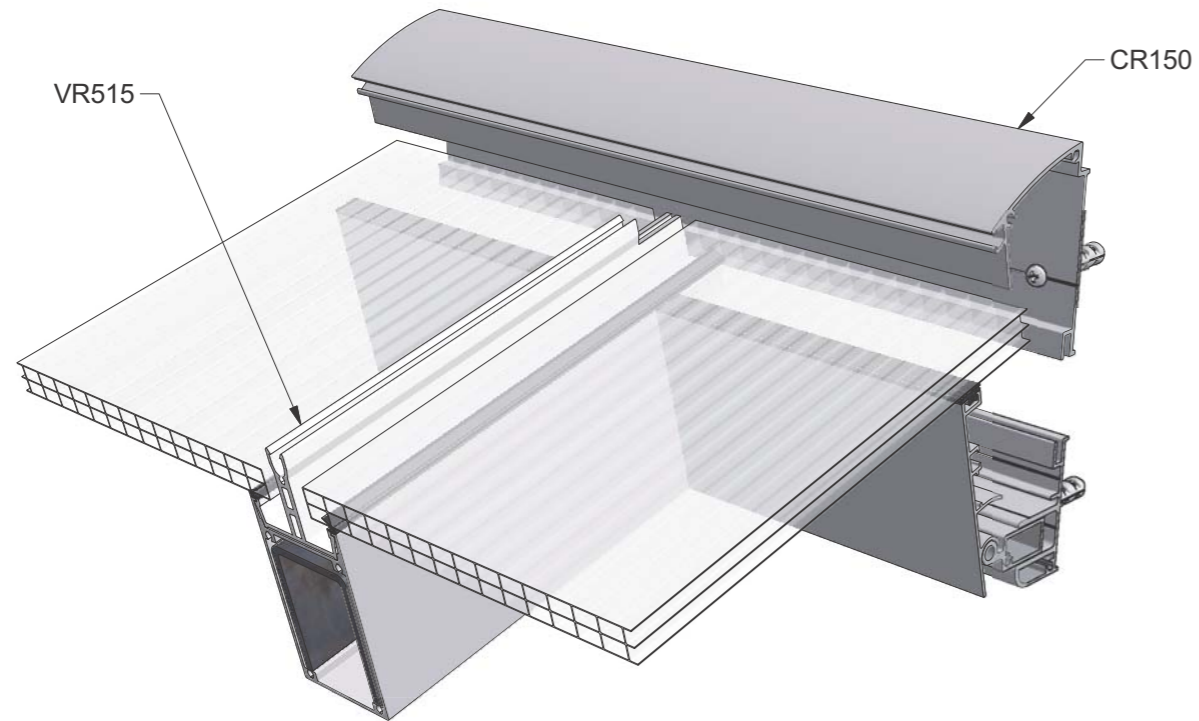

Montage CR150.idw

MONTAGE MC055
MONTAGE MC055
MONTAGE MC055
MONTAGE MC055

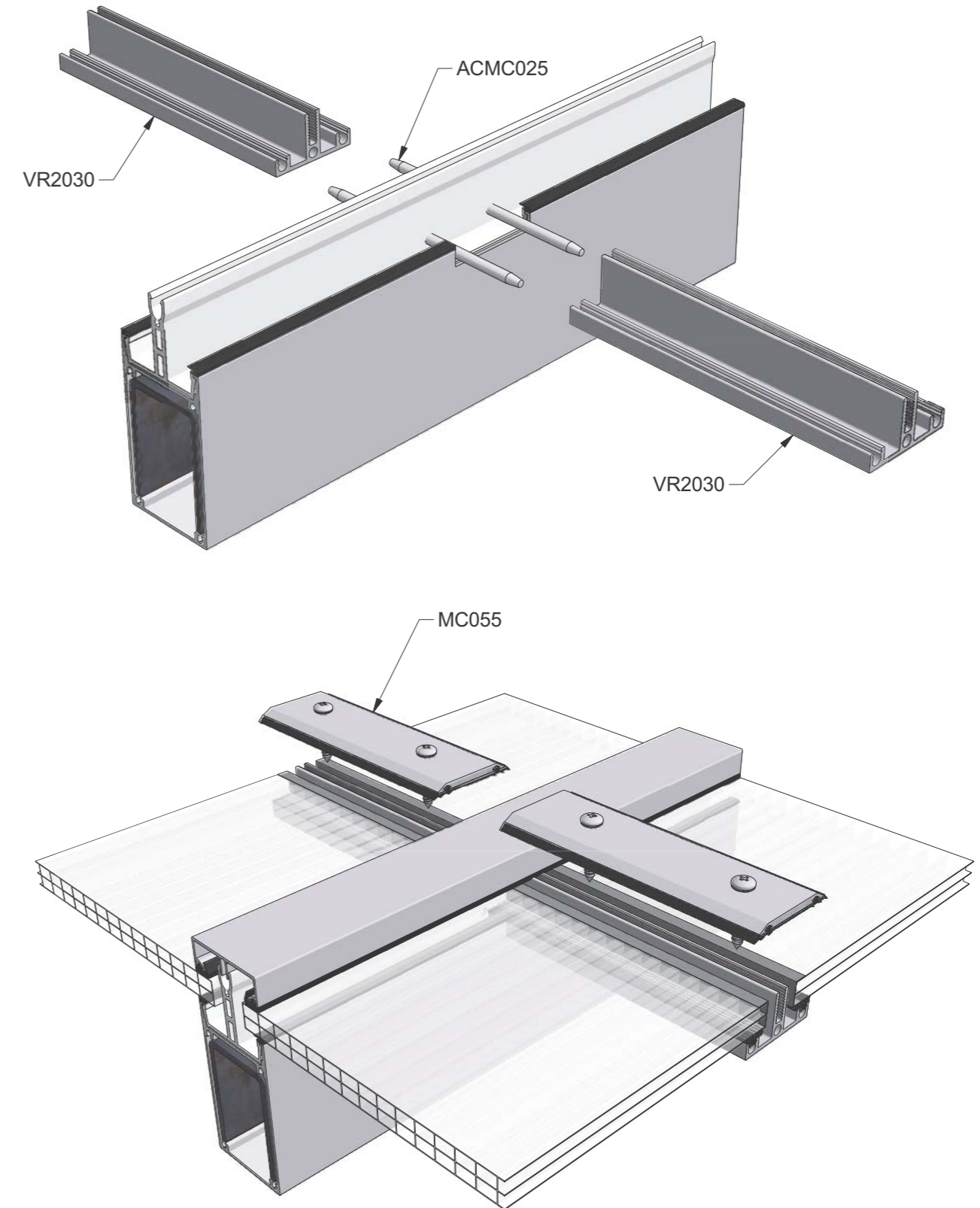
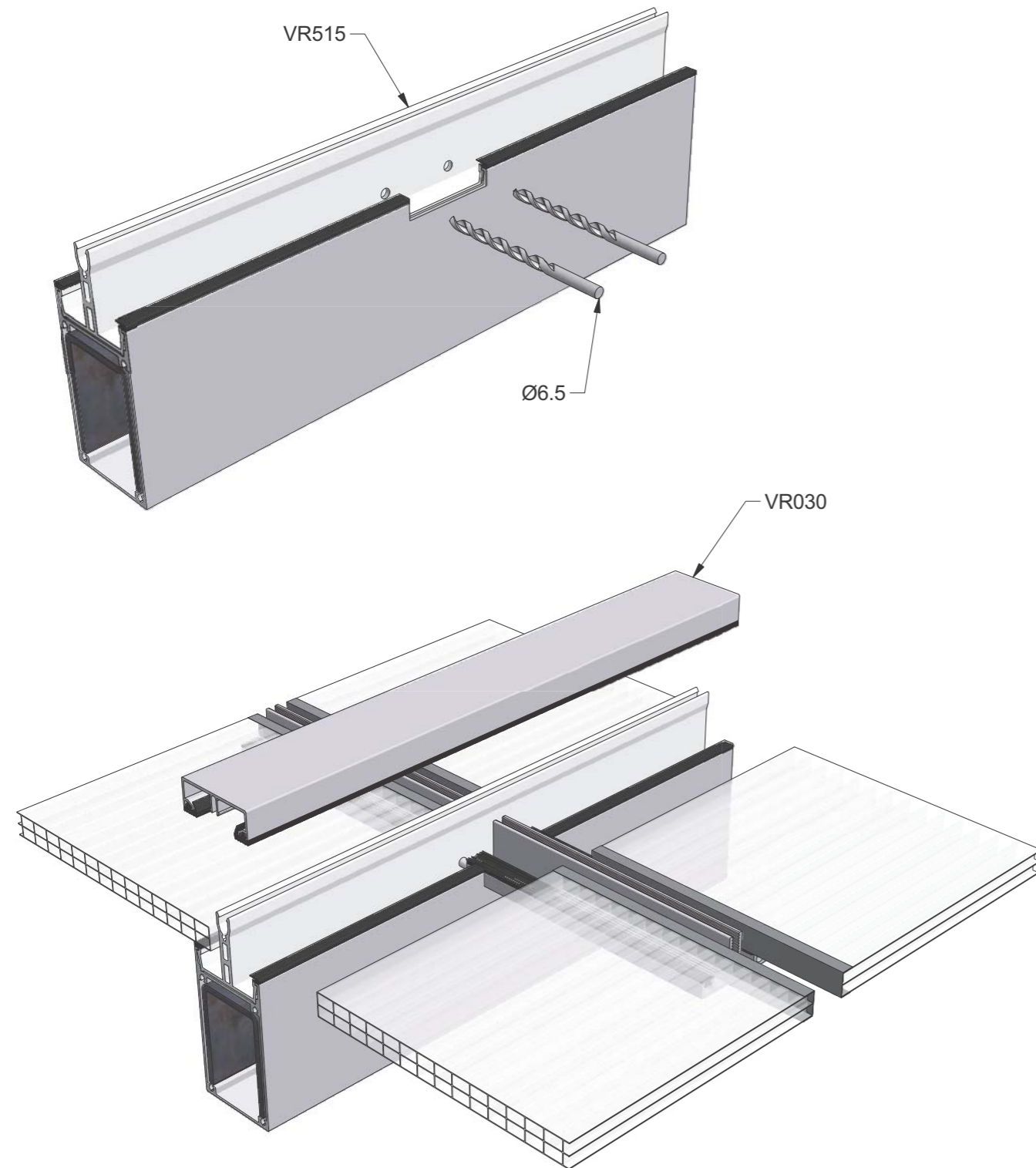

MONTAGE MC055
MONTAGE MC055
MONTAGE MC055
MONTAGE MC055

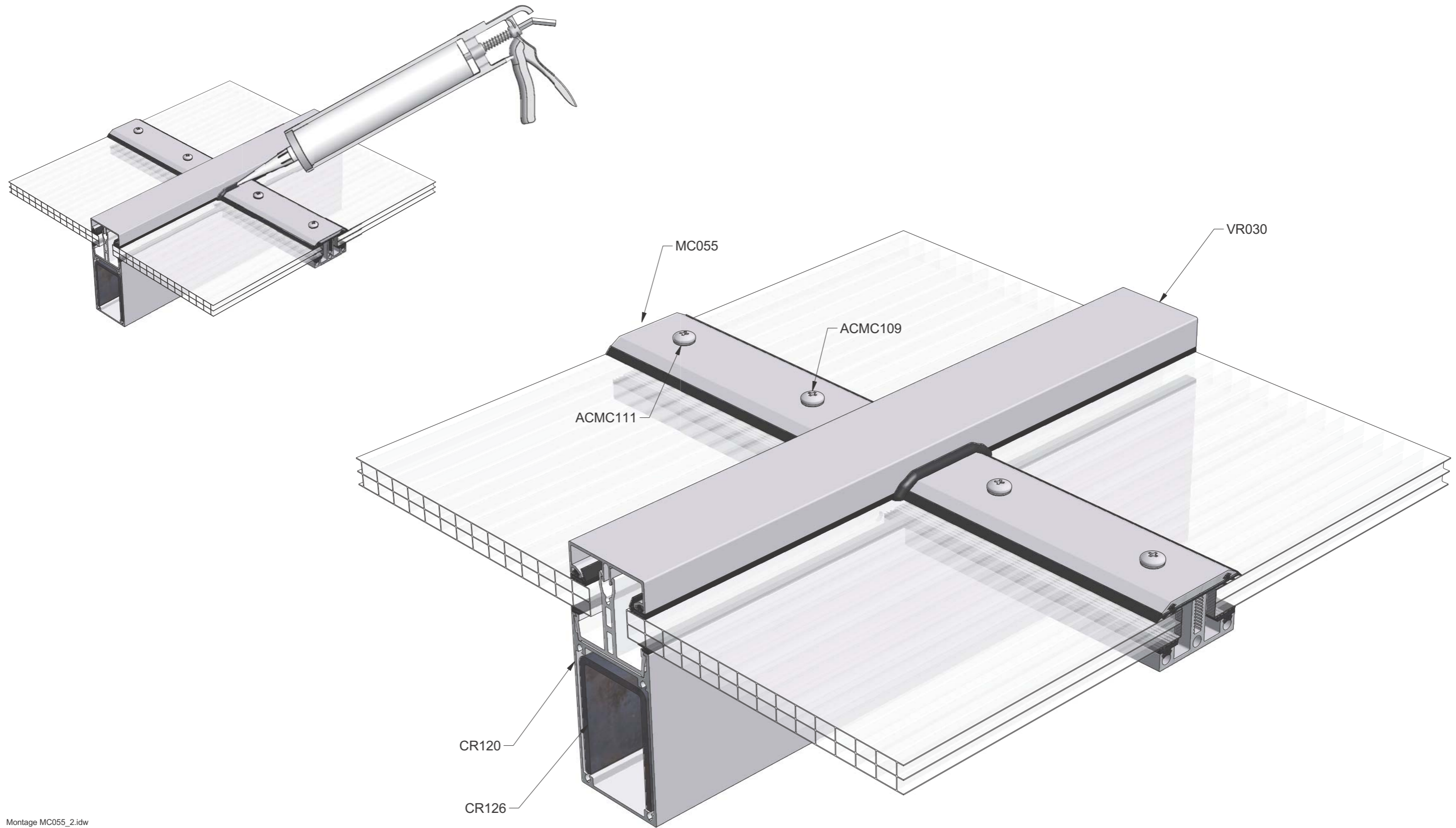

Montage MC055_2.idw

MONTAGE CR105
MONTAGE CR105
MONTAGE CR105
MONTAGE CR105

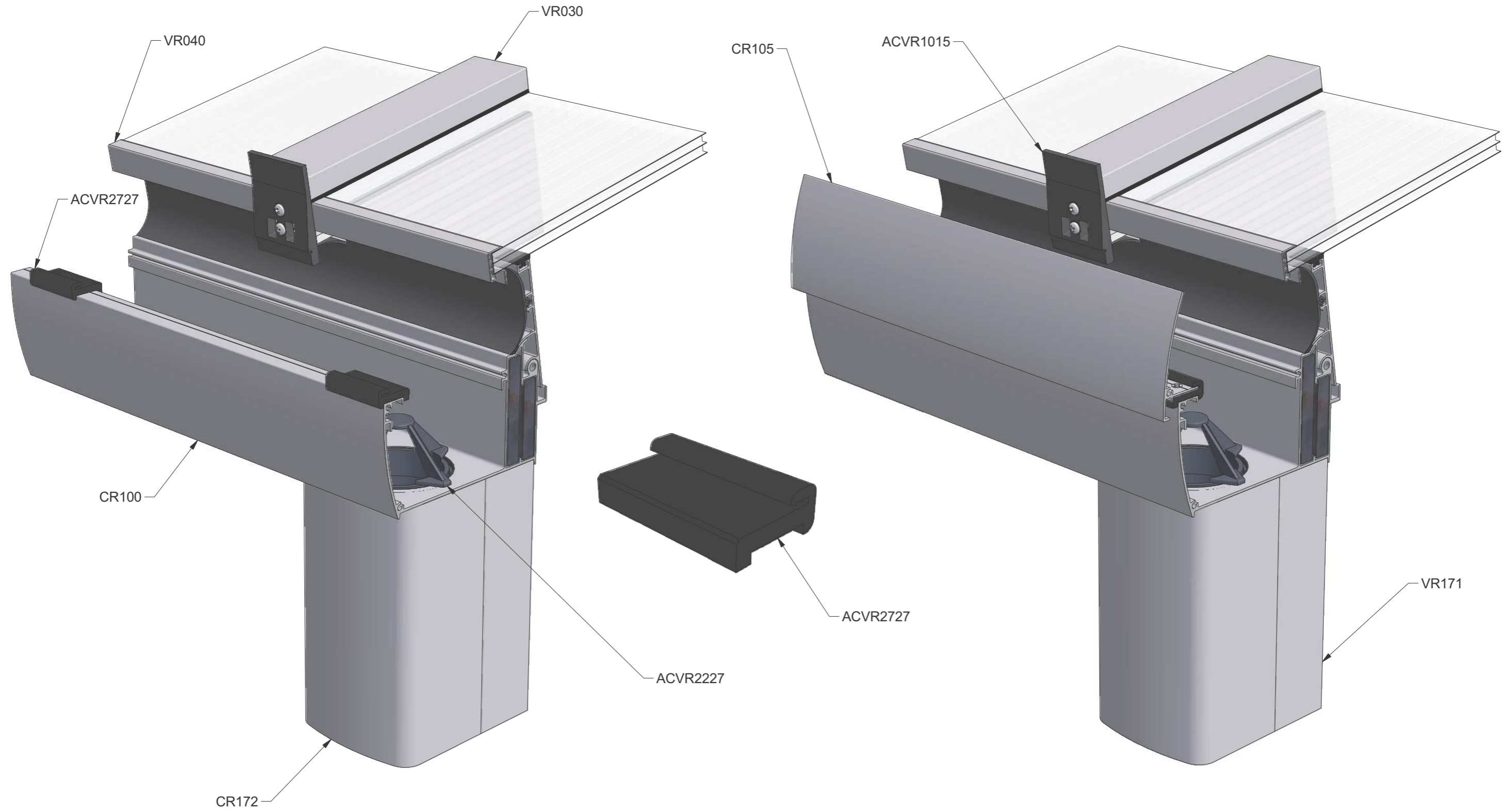

Montage CR105.idw